



Priority

Category Partitioning Testing Tool

OOPT
Stage 2040

Team 4

201311265 김상원
201311269 김제헌
201311297 이상명
201210194 김정환



Team4

Presentation Index

- 1. Revise Plan**
- 2. Priority Score Calc. Algorithm**
- 3. Define UI**
- 4. Design Real Use Cases**
- 5. Define Interaction Diagrams**
- 6. Define Design Class Diagrams**
- 7. Design Traceability Analysis**



1.

Revise Plan



Use Case 수정

OOPT 2030 ver1.3 -> OOPT 2030 ver2.2

Use Case	Make new specification file
	Set Category
	Set representative value
	Set property
수정 전	같은 이름이 존재하면 Check same name을 통해 처리한다
수정 후	같은 이름이 존재하면 예외처리한다.

Define Domain Model

OOPT 2030 ver1.3

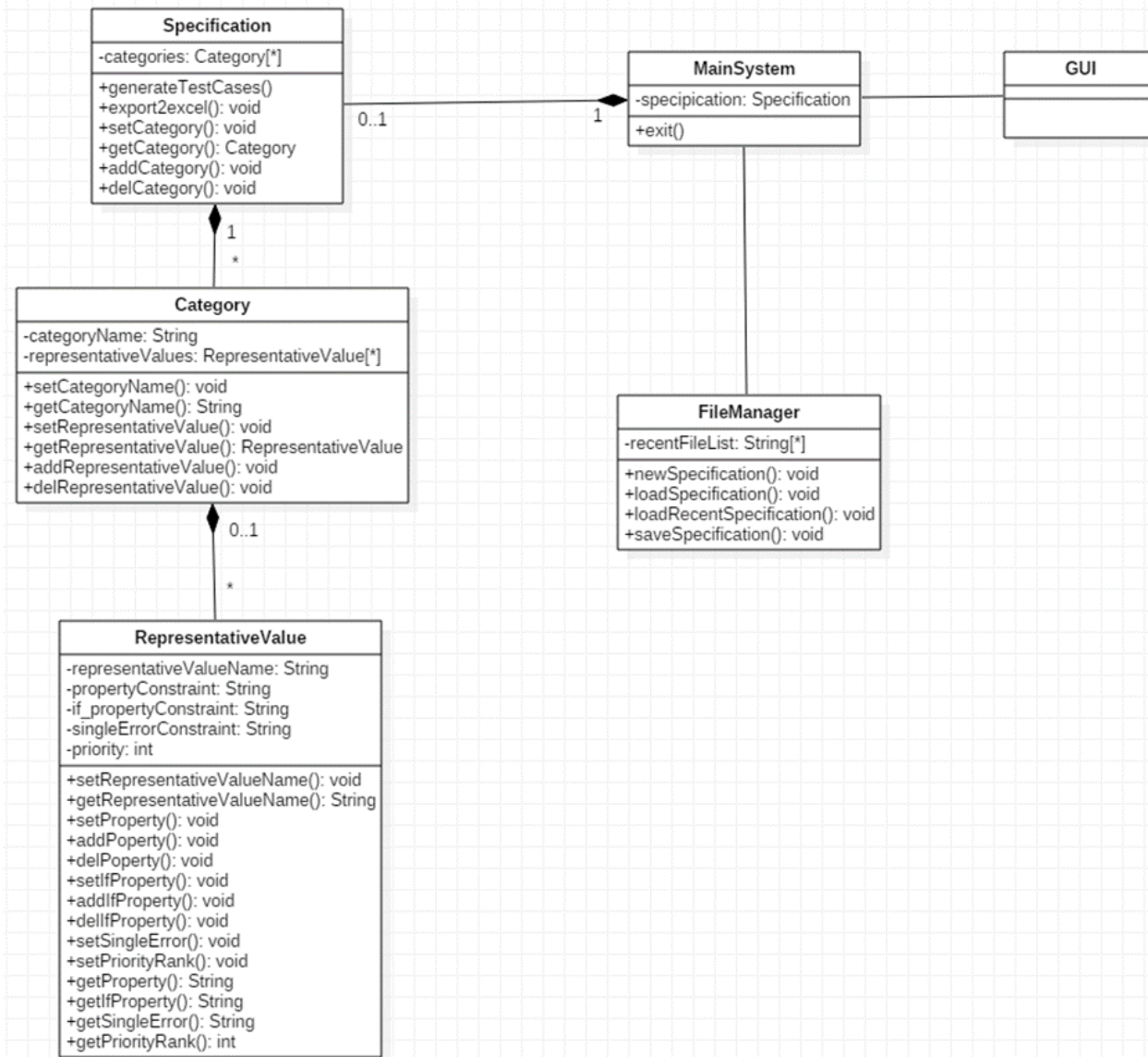



Define Domain Model

OOPT 2030 ver2.2

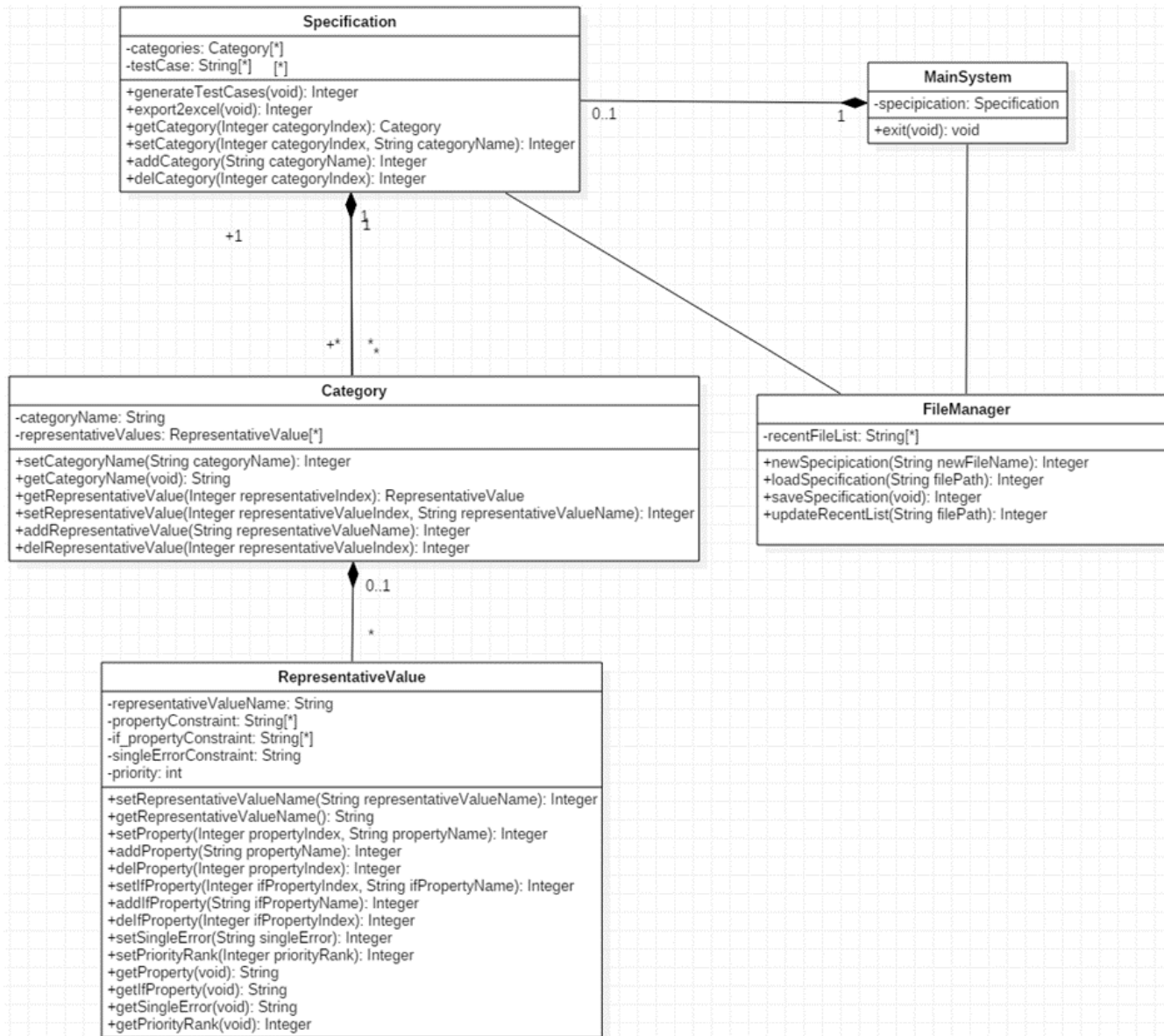



Analyze Traceability Analysis

OOPT 2030 ver1.1

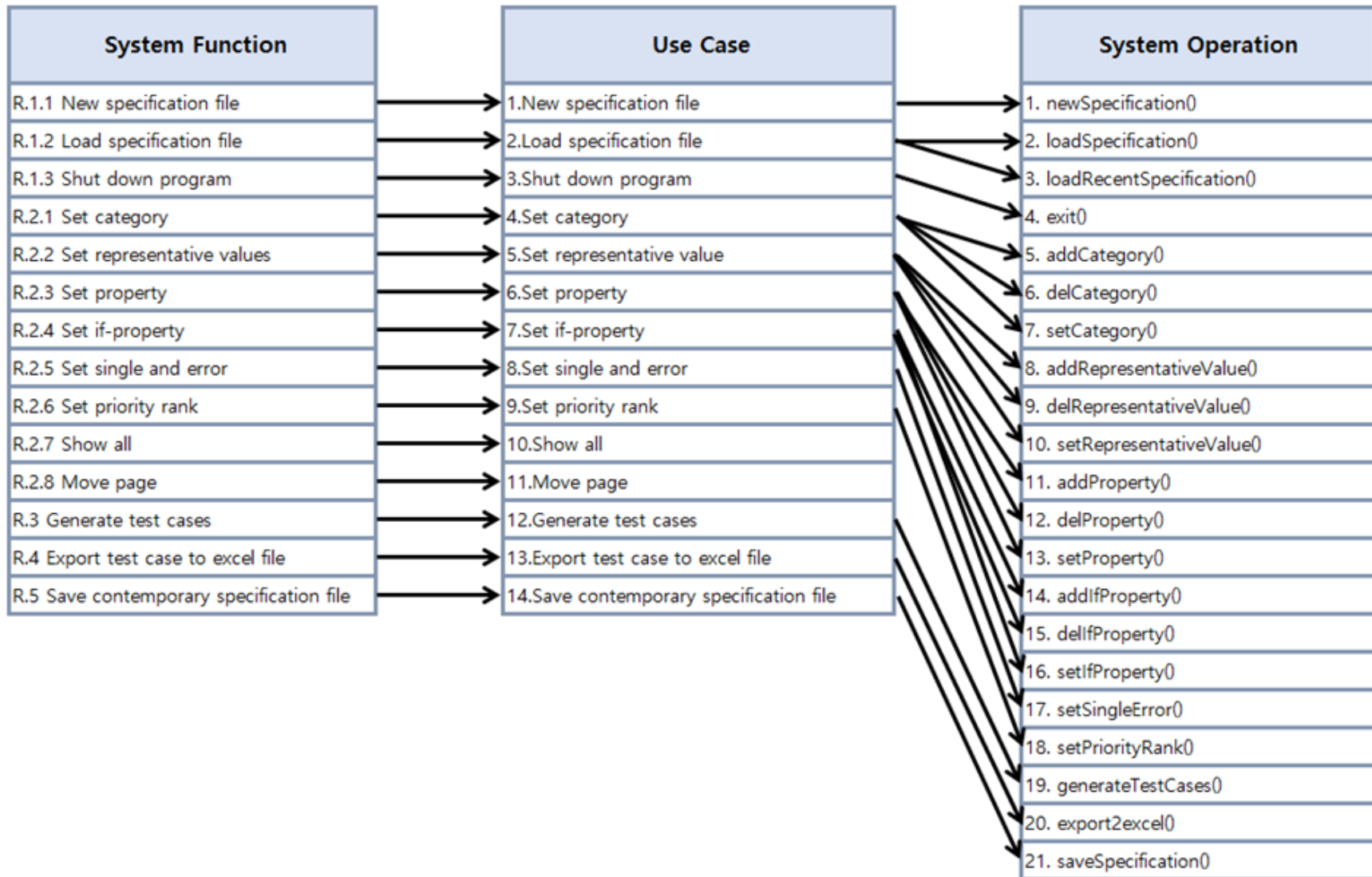



Analyze Traceability Analysis

OOPT 2030 ver2.2

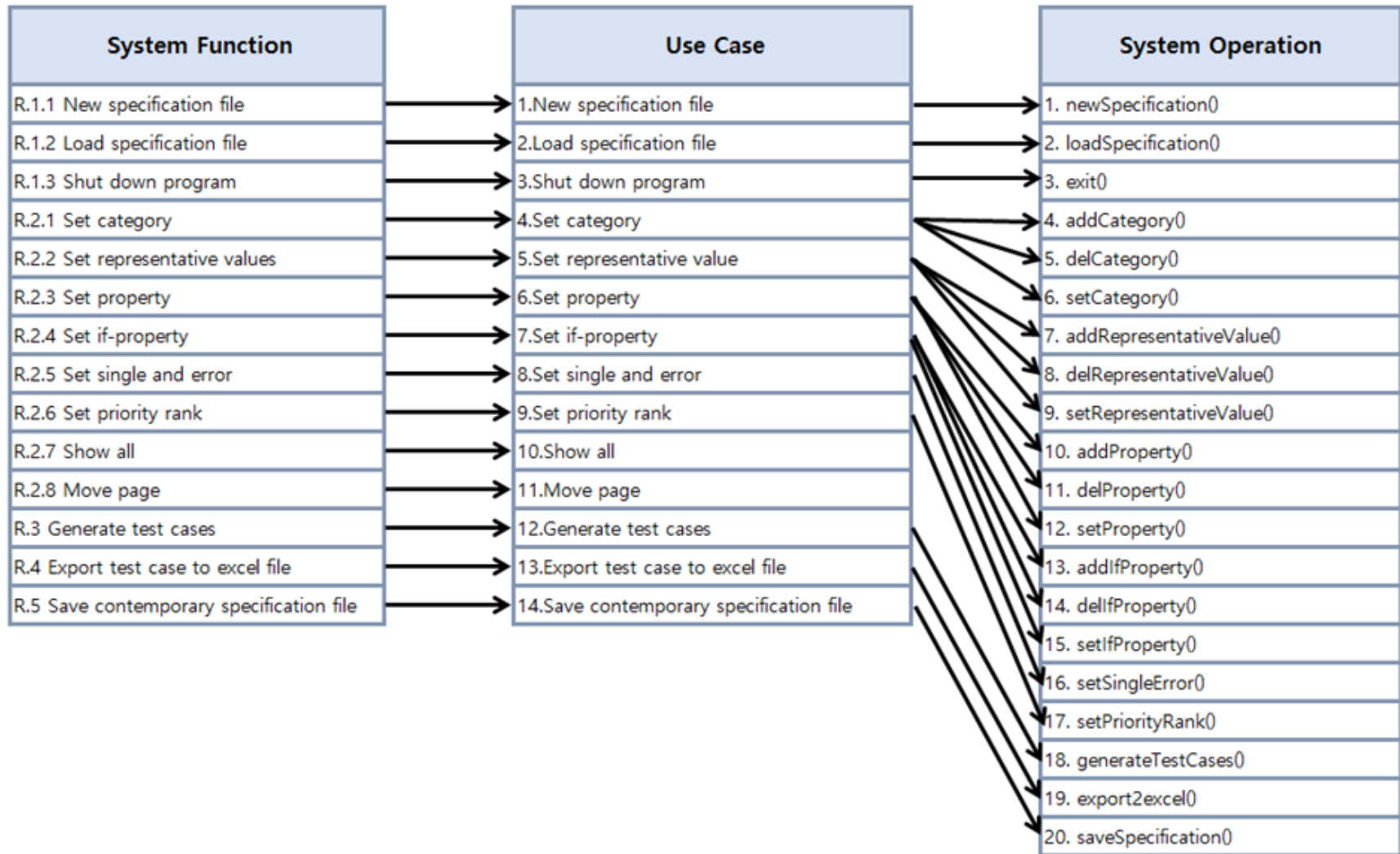



2.

Priority Score Calc. Algorithm



우선순위 1~5점

점수 합산하여 정렬된
테스트케이스 목록 제공



총점이 동점

C1	C2	C3
A 2	A 2	A 2
B 1	B 1	B 4

총점은

AAA $2+2+2 = 6$

BBB $1+1+4 = 6$

하지만 BBB가 더 우선순위가 높다.

우선순위 점수의 최대값이 AAA 2 < BBB 4



우선순위의 최대값

C1	C2	C3
A 2	A 2	A 2
B 1	B 1	B 3

총점은

AAA $2+2+2 = 6$

BBB $1+1+3 = 5$

하지만 BBB가 더 우선순위가 높다.

우선순위 점수의 최대값이 AAA 2 < BBB 3



총점

C1	C2	C3
A 2	A 2	A 2
B 1	B 1	B 3

곱하기(bit shift) 예시

AAA $2*2+2*2+2*2 = 12$

BBB $1*1+1*1+3*4 = 14$

곱하기 전 총점 AAA 6 > BBB 5

곱하기 후 총점 AAA 12 < BBB 14



그래도 총점이 같을
때는?

Priority 최대값 비교



최대값까지 같을
때는?

표준편차 이용?

아직 논의 중..



예시

AAAAA	2	5	2	2	2
BBBBB	2	2	2	5	2
CCCCC	...				
DDDDD	...				
ABCAB	...				
...					

- 두번째 카테고리 priority 점수 평균은 2.xx
- 네번째 카테고리 priority 점수 평균은 4.xx

그렇다면 두번째 카테고리의 5점이 네번째
카테고리의 5점보다 더 우선순위가 높은가?



3.

Define UI

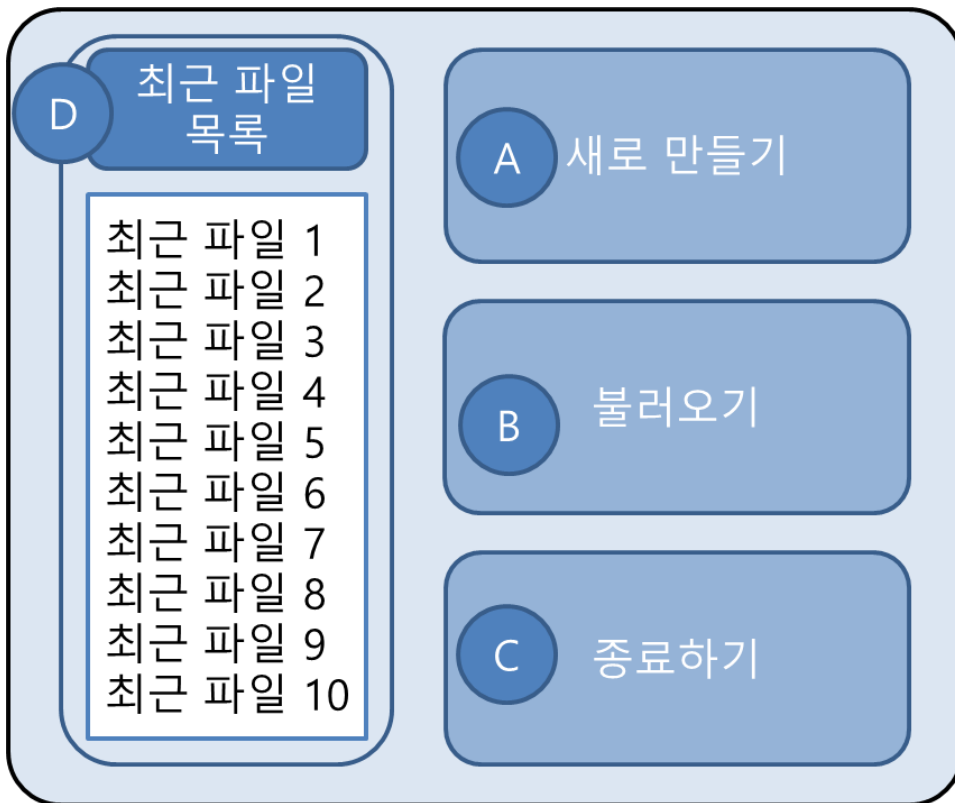



3. Define UI

새 파일 이름 :

E (points to the text input field)

F (points to the '이름 결정' button)

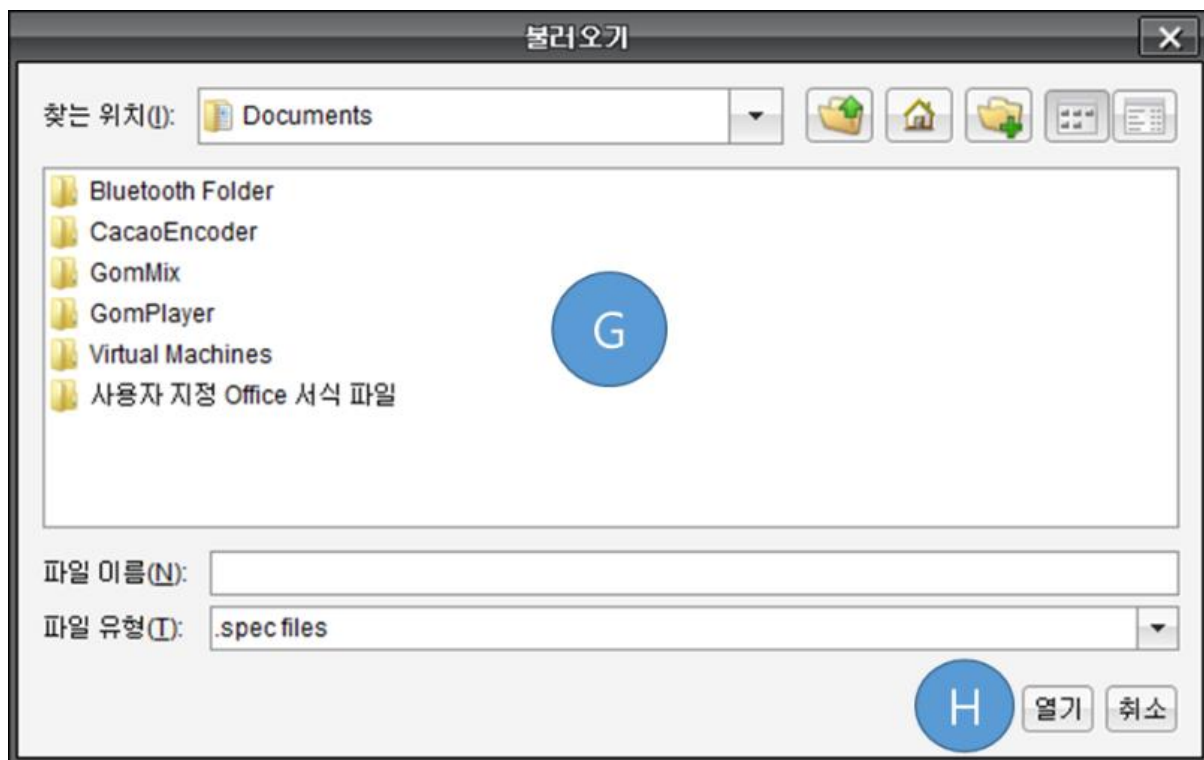



저장 a

1단계 > 2단계 > 3단계 > 4단계 > 5단계 > 6단계 > 7단계

Category 목록

K	Open File 확장자	-	J
	파일 이름 중복	-	
	⋮	+	I

L

다음 단계



저장 a

1단계 > 2단계 > 3단계 > 4단계 > 5단계 > 6단계 > 7단계

Category 목록

Open File 확장자

- File.c
- File.ect

파일 이름 중복

.....

이전 단계

다음 단계

Annotations: O, N, M, P, L

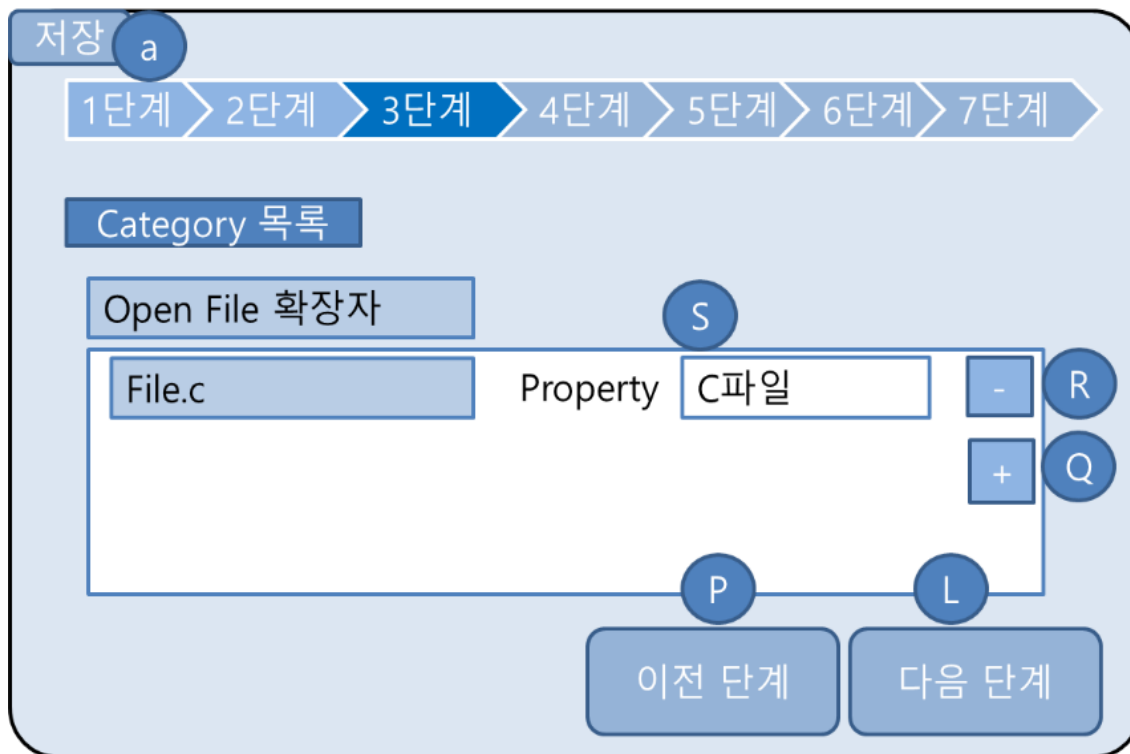

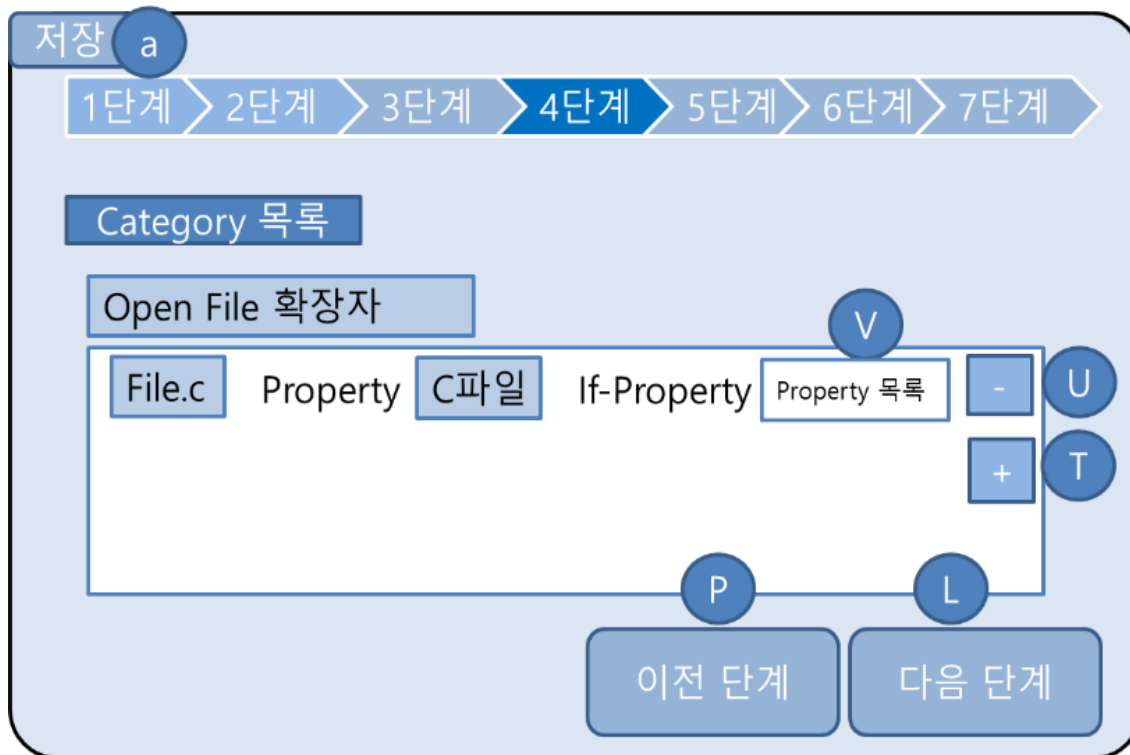

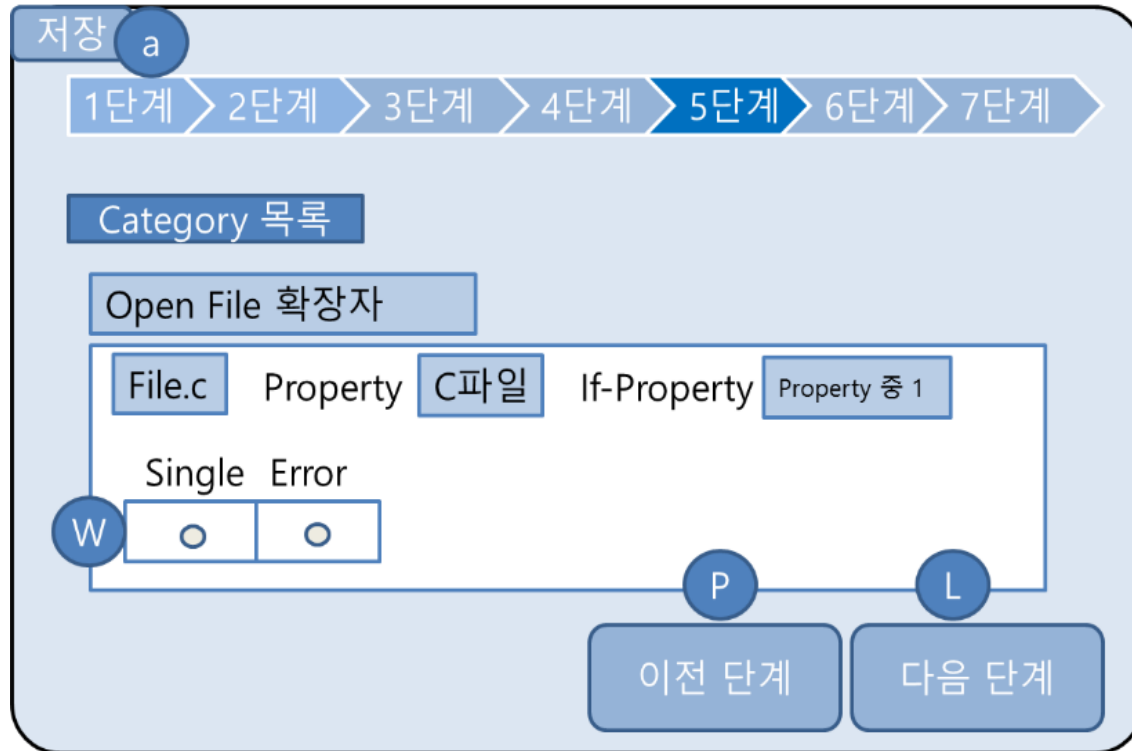



저장 a

1단계 > 2단계 > 3단계 > 4단계 > 5단계 > 6단계 > 7단계

Category 목록

Open File 확장자

File.c Property C파일 If-Property Property 중 1

Single Error Priority₁ 2 3 4 5

X

P L

이전 단계 다음 단계



저장 a

1단계 > 2단계 > 3단계 > 4단계 > 5단계 > 6단계 > 7단계

Category 목록 모든 Specification 정보 최종 확인

Open File 확장자

File.c Property C파일 If-Property Property 중 1

Single Error Priority₁ 2 3 4 5

<input type="radio"/>	<input type="radio"/>	<input checked="" type="radio"/>	<input type="radio"/>	<input type="radio"/>	<input type="radio"/>	<input type="radio"/>
-----------------------	-----------------------	----------------------------------	-----------------------	-----------------------	-----------------------	-----------------------

P L

이전 단계 완료 하기



Category Partitioning Test Case가
총 xxx개 생성되었습니다.

Y
엑셀로 저장

Z
처음 화면



4.

Design Real Use Cases



Use Case	Make new specification file
Actor	User
Purpose	Test case generate을 위해 새로운 specification 파일을 작성한다.
Overview	초기화면에서 '새로 만들기' 버튼을 클릭하면 저장할 파일 이름을 입력 받는 화면이 출력되어, 입력 받은 이름으로 새로운 specification파일을 생성한다. 최근 파일 항목에 반영한다.
Type	Primary
Cross Reference	Funtional Requirements : R1.1
Pre-Requisites	N/A
UI Widgets	Window-1, Window-2
Typical Courses of Events	(A) : Actor, (S):System 1. (A) Window-1의 A를 누른다. 2. (S) specification 파일 이름을 입력 받는 단계로 넘어간다. 3. (A) E에 이름을 입력한다. 4. (A) F를 누른다. 5. (S) 지정된 이름의 specification 파일을 만든다. 6. (S) 생성된 specification 파일을 recent file list에 갱신한다. 7. (S) Set category page로 이동한다.
Alternative Courses of Events	N/A
Exceptional Courses of Events	E. 입력한 이름과 같은 파일이 존재하면 예외처리한다.



Use Case	Load specification file
Actor	User
Purpose	이미 작성했던 specification중 저장한 파일을 불러온다.
Overview	초기화면에서 '불러오기' 버튼을 클릭하거나, 최근 파일 목록 중 하나를 선택하여 기존 작성한 명세를 불러온다. 최근 파일 항목에 반영한다
Type	Primary
Cross Reference	Funtional Requirements : R1.2
Pre-Requisites	불러올 specification파일 또는 recent file list에 specification 파일이 있어야 한다.
UI Widgets	Window-1, Window-3
Typical Courses of Events	<p>(A) : Actor, (S):System</p> <ol style="list-style-type: none">1.1 (A) Window-1의 B를 누른다.1.2 (S) specification 파일을 찾기 위한 Window-3으로 넘어간다.1.3. (A) G에서 specification 파일을 선택한다.1.4. (A) H를 누른다.1.5. (S) 선택된 specification 파일을 불러 읽는다.1.6. (S) 선택된 specification 파일을 recent file list에 갱신한다.1.7. (S) specification 파일이 저장된 시점의 단계를 보여준다. <ol style="list-style-type: none">2.1. (A) Window-1의 D에서 한 항목을 더블 클릭한다.2.2. (S) 선택된 specification 파일을 불러 읽는다.2.3. (S) 선택된 specification 파일의 recent file list 순위를 갱신한다.2.4. (S) specification 파일이 저장된 시점의 단계를 보여준다.
Alternative Courses of Events	N/A
Exceptional Courses of Events	E. 최근 파일 항목에 있던 파일이 위치가 이동되거나 삭제되어 주소가 변경되었을 때, 오류 메시지를 호출한다.



Use Case	Shut down program
Actor	User
Purpose	프로그램 종료
Overview	초기화면에서 종료하기 버튼을 클릭하여 프로그램을 종료한다.
Type	Primary
Cross Reference	Funtional Requirements : R1.3
Pre-Requisites	N/A
UI Widgets	Window-1
Typical Courses of Events	(A) : Actor, (S):System 1. (A) Window-1의 C를 누른다. 2. (S) 프로그램을 종료한다.
Alternative Courses of Events	N/A
Exceptional Courses of Events	N/A



Use Case	Set category
Actor	User
Purpose	Specification의 각 category를 편집한다.
Overview	새로운 category를 추가 또는 이미 작성된 category를 삭제 또는 이미 작성된 category를 수정한다.
Type	Primary
Cross Reference	Funtional Requirements : R2.1, R2.2, R.2.8
Pre-Requisites	N/A
UI Widgets	Window-4
Typical Courses of Events	<p>(A) : Actor, (S):System</p> <p>1.1. (A) Category 목록 밑에 I을 누른다. 1.2. (S) category 항목 란을 추가한다. 1.2. (A) 추가된 K에 category 이름을 입력한다. 1.3. (S) category 이름들을 specification에 반영한다.</p> <p>2.1. (A) Category 목록 밑에 있는 J를 누른다. 2.2. (S) 선택된 category 항목과 하위 representative values항을 삭제한다. 2.3. (S) 삭제된 category 값과 하위 representative values값들을 specification에 반영한다.</p> <p>3.1. (A) Category 목록 밑에 있는 K을 누른다. 3.2. (A) 선택된 category 항목의 새로운 category 이름을 입력한다. 3.3. (S) 선택된 category 항목의 이름을 새로운 이름으로 변경한다.</p>
Alternative Courses of Events	N/A
Exceptional Courses of Events	E. 같은 category 이름이 존재하면 예외처리한다.



Use Case	Set representative values
Actor	User
Purpose	Specification의 각 representative value를 편집한다.
Overview	새로운 representative value 를 추가 또는 이미 작성된 representative value 를 삭제 또는 이미 작성된 representative value를 수정한다.
Type	Primary
Cross Reference	Functional Requirements : R2.1, R2.2, R2.3, R.2.8
Pre-Requisites	N/A
UI Widgets	Window-5
Typical Courses of Events	<p>(A) : Actor, (S):System</p> <p>1.1. (A) Category 항목 안에 있는 M을 누른다.</p> <p>1.2. (S) category 항목 안에 representative value 항목 란을 추가한다.</p> <p>1.2. (A) 추가된 O에 representative value 이름을 입력한다.</p> <p>1.3. (S) representative value 이름들을 specification에 반영한다.</p> <p>2.1. (A) Category 항목 안에 있는 N을 누른다.</p> <p>2.2. (S) 선택된 representative value 항목 란을 삭제한다.</p> <p>2.3. (S) 삭제된 representative values값을 specification에 반영한다.</p> <p>3.1. (A) Category 항목 안의 O를 누른다.</p> <p>3.2. (A) 선택된 representative value 항목의 새로운 representative value 이름을 입력한다.</p> <p>3.3. (S) 선택된 representative value 항목의 이름을 새로운 이름으로 변경한다.</p>
Alternative Courses of Events	N/A
Exceptional Courses of Events	E. 같은 representative value 이름이 존재하면 예외처리한다.



Use Case	Set property
Actor	User
Purpose	Specification의 각 property constraint를 설정한다.
Overview	각 representative value마다 property constraint를 부여하거나 삭제 또는 수정할 수 있다.
Type	Primary
Cross Reference	Funtional Requirements : R2.2, R2.3, R2.4, R.2.8
Pre-Requisites	N/A
UI Widgets	Window-6
Typical Courses of Events	<p>(A) : Actor, (S):System</p> <ol style="list-style-type: none">1.1. (A) representative value의 Q을 누른다.1.2. (A) 새로운 property constraint 항목의 이름을 입력한다.1.3. (S) property constraint를 추가한다. <ol style="list-style-type: none">2.1. (A) representative value의 R을 누른다.2.2. (S) property constraint 항목을 삭제한다. <ol style="list-style-type: none">3.1. (A) representative value의 S를 누른다.3.2. (A) 새로운 property constraint 이름을 입력한다.3.3. (S) property constraint 항목의 이름을 새로운 이름으로 변경한다.
Alternative Courses of Events	N/A
Exceptional Courses of Events	E. 같은 property 이름이 존재하면 예외처리한다.



Use Case	Set if-property
Actor	User
Purpose	Specification의 각 if-property constraint를 설정한다.
Overview	각 representative value마다 기존에 설정된 property constraints 중에서 if-property constraint를 추가 또는 삭제 또는 수정할 수 있다.
Type	Primary
Cross Reference	Functional Requirements : R2.3, R2.4, R2.5, R.2.8
Pre-Requisites	N/A
UI Widgets	Window-7
Typical Courses of Events	<p>(A) : Actor, (S):System</p> <ol style="list-style-type: none">1.1. (A) representative value의 T를 누른다.1.2. (A) V에서 하나의property constraint 항목을 선택한다.1.3. (S) 선택된 property constraint를 추가한다. <ol style="list-style-type: none">2.1. (A) representative value의 기존 if-property constraint 항목을 선택한 후 U를 누른다.2.2. (S) 선택된 if-property constraint를 삭제한다. <ol style="list-style-type: none">3.1. (A) representative value의 기존 if-property constraint 항목을 선택한 후 V를 누른다.3.2. (A) V에서 하나의 property constraint 항목을 선택한다.3.3. (S) 기존의 if-property constraint 항목을 새롭게 선택된 항목으로 변경한다.
Alternative Courses of Events	N/A
Exceptional Courses of Events	N/A



Use Case	Set single and error
Actor	User
Purpose	Specification의 각 single 또는 error constraint를 설정한다.
Overview	각 representative value마다 single 또는 error constraint를 부여하거나 지울 수 있다.
Type	Primary
Cross Reference	Funtional Requirements : R2.4, R2.5, R2.6, R.2.8
Pre-Requisites	N/A
UI Widgets	Window-8
Typical Courses of Events	(A) : Actor, (S):System 1. (A) W에서 single 또는 error를 선택한다. 2. (S) single 또는 error constraint들을 specification에 반영한다.
Alternative Courses of Events	N/A
Exceptional Courses of Events	N/A



Use Case	Set priority rank
Actor	User
Purpose	Specification의 각 priority를 설정한다.
Overview	입력된 representative value들에게 사용자가 priority(중요도)를 부여한다. 입력할 수 있는 priority(중요도)는 총 5단계로 정해진다.
Type	Primary
Cross Reference	Functional Requirements : R2.5, R2.6, R2.7, R.2.8
Pre-Requisites	N/A
UI Widgets	Window-9
Typical Courses of Events	(A) : Actor, (S):System 1. (A) X의 1, 2, 3, 4, 5 중에서 선택한다. 2. (S) priority들을 specification에 반영한다.
Alternative Courses of Events	N/A
Exceptional Courses of Events	N/A



Use Case	Show all
Actor	User
Purpose	입력한 전체 specification을 볼 수 있다.
Overview	보여지는 specification을 확인하고 문제가 있으면 입력단계로 돌아갈 수 있다. '완료 하기'버튼을 누르는 경우 test case generate이 수행된다.
Type	Primary
Cross Reference	Funtional Requirements : R2.6, R2.7, R.2.8
Pre-Requisites	N/A
UI Widgets	Window-10
Typical Courses of Events	(A) : Actor, (S):System 1. (A) Window-10에서 지금까지 입력한 specification 이 맞는지 확인한다.
Alternative Courses of Events	N/A
Exceptional Courses of Events	N/A



Use Case	Move page
Actor	User
Purpose	각 단계에서 다른 단계로 이동할 수 있다.
Overview	Specification을 작성하는 각 단계에서 이전, 다음 혹은 초기 단계로 이동한다.
Type	Primary
Cross Reference	Functional Requirements : R.2.1, R.2.2, R.2.3, R.2.4, R.2.5, R.2.6, R.2.7, R.2.8, R 4
Pre-Requisites	N/A
UI Widgets	Window-4, 5, 6, 7, 8, 9, 10, 11
Typical Courses of Events	(A) : Actor, (S):System 1.1. (A) P를 누른다. 1.2. (S) 기존 단계의 이전 단계로 이동한다. 2.1. (A) L을 누른다. 2.2. (S) 기존 단계의 다음 단계로 이동한다. 3.1. (A) Z을 누른다. 3.2. (S) 처음 화면으로 이동한다.
Alternative Courses of Events	N/A
Exceptional Courses of Events	N/A



Use Case	Generate test cases
Actor	User
Purpose	Specification이 확인되면 test case generate가 시작된다.
Overview	입력된 specification을 통해 test case를 만들고 그 총 개수를 화면을 통해 사용자에게 알려준다. 사용자는 생성된 test cases의 수를 보고 generate이 잘 되었는지 판단할 수 있다.
Type	Primary
Cross Reference	Funtional Requirements : R.2.7, R.2.8, R 3, R 4
Pre-Requisites	N/A
UI Widgets	Window-10
Typical Courses of Events	(A) : Actor, (S):System 1. (A) L을 누른다. 2. (S) 입력된 specification을 통해 test case를 만든다. 3. (S) 총 개수를 새로운 화면을 통해 사용자에게 알려준다.
Alternative Courses of Events	N/A
Exceptional Courses of Events	N/A



Use Case	Export test case to excel file
Actor	User
Purpose	Test cases를 엑셀 파일로 저장한다.
Overview	Test case generate이 끝난 후 생성된 test cases를 엑셀 파일로 저장한다 생성된 엑셀파일은 설정한 Priority순으로 정렬 된다.
Type	Primary
Cross Reference	Funtional Requirements : R 3, R 4
Pre-Requisites	N/A
UI Widgets	Window-11
Typical Courses of Events	(A) : Actor, (S):System 1. (A) Y를 누른다. 2. (S) 생성된 test cases를 Priority순으로 정렬 한다. 3. (S) Priority순으로 정렬된 test cases를 엑셀 파일로 저장한다.
Alternative Courses of Events	N/A
Exceptional Courses of Events	N/A



Use Case	Save contemporary specification file
Actor	User
Purpose	현재까지의 작업 상태를 저장한다.
Overview	specification입력 중 각 단계를 완료하거나 중간저장 버튼을 누르면, 현재까지의 작업 상태를 저장한다. 저장한 후 Load specification을 통해 언제든지 불러올 수 있다.
Type	Primary
Cross Reference	Functional Requirements : R.2.1, R.2.2, R.2.3, R.2.4, R.2.5, R.2.6, R.2.7, R.5
Pre-Requisites	N/A
UI Widgets	Window-4, 5, 6, 7, 8, 9, 10
Typical Courses of Events	(A) : Actor, (S):System 1. (A) a를 누른다. 2. (S) 현재까지의 작업 상태를 specification 파일로 저장한다.
Alternative Courses of Events	N/A
Exceptional Courses of Events	N/A



5.

Define Interaction Diagrams



[newSpecification]

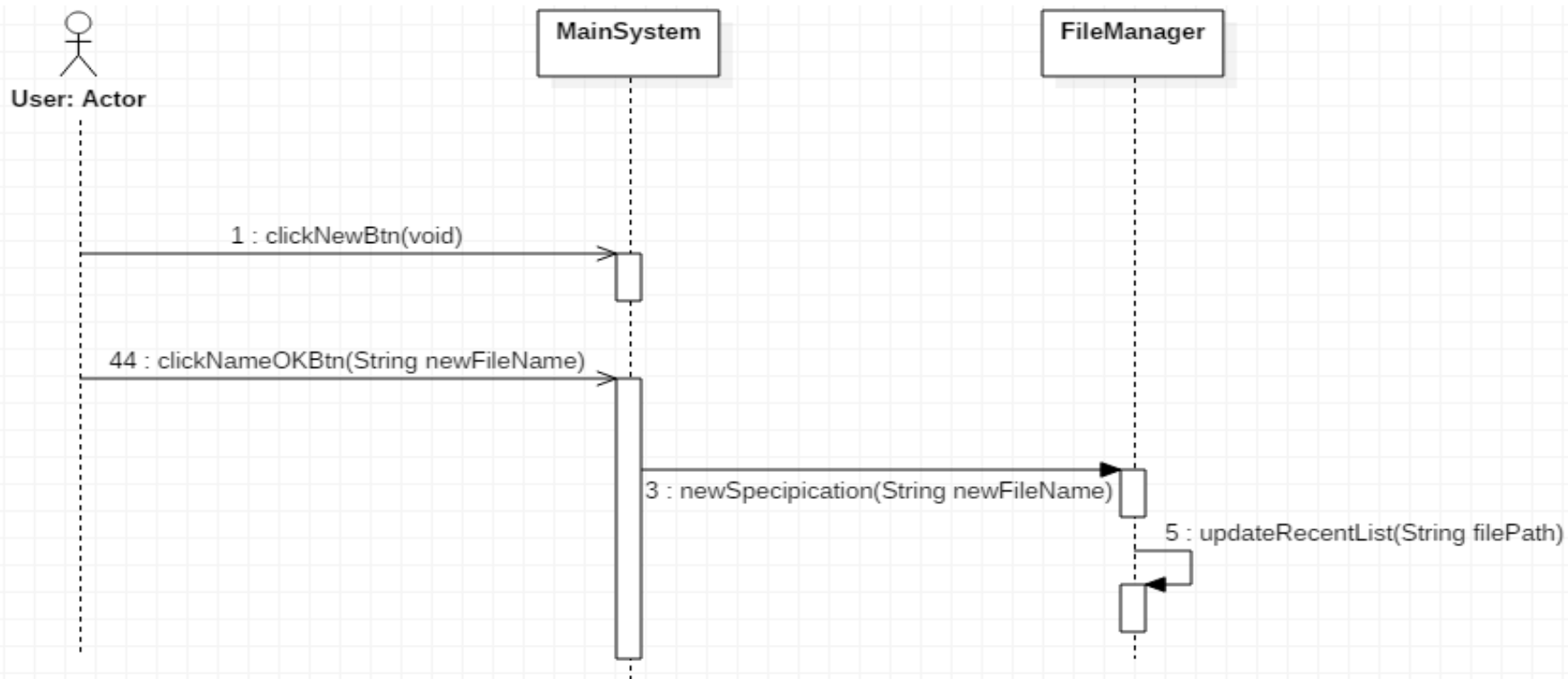



[loadSpecification]

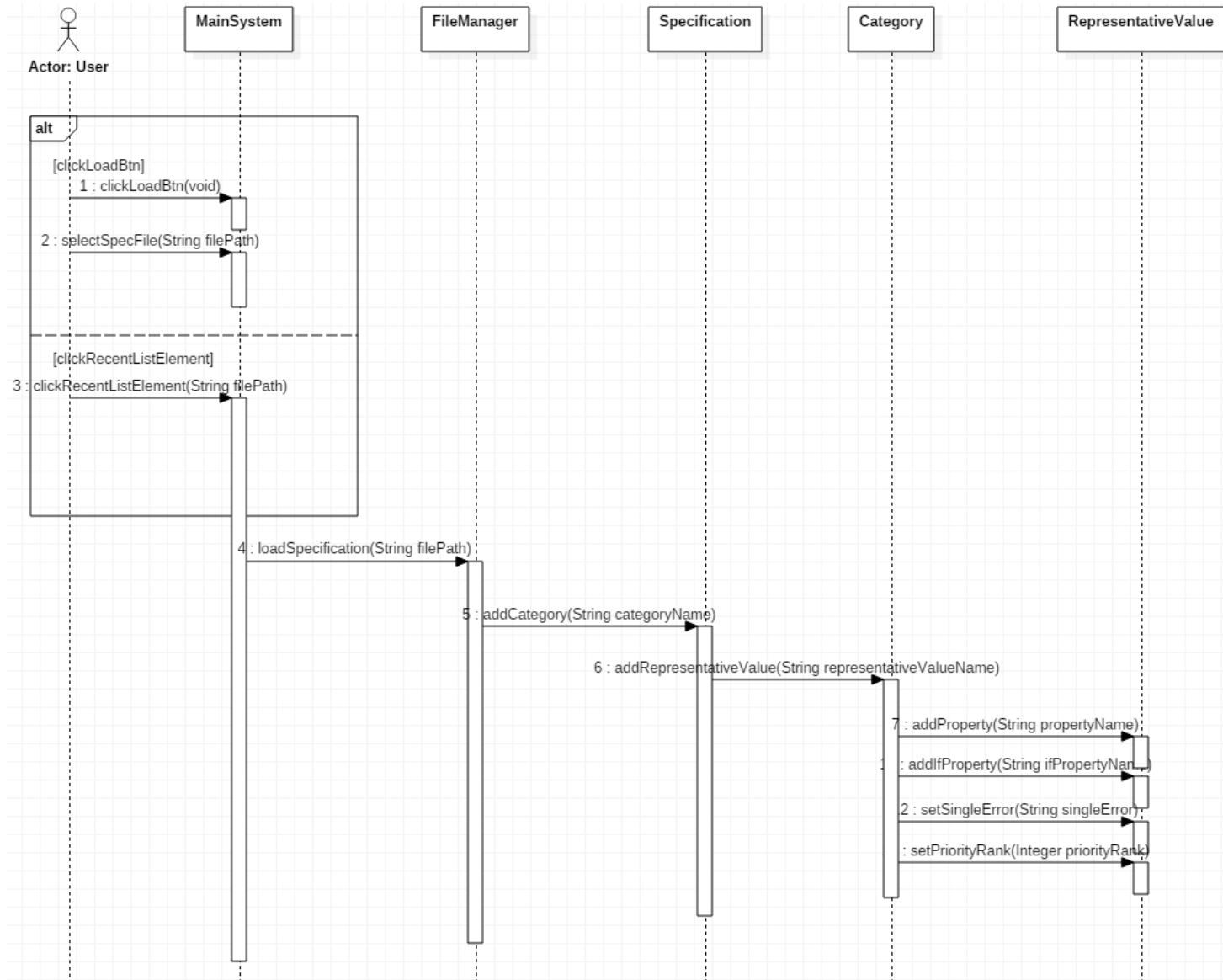



[shutdownProgram]

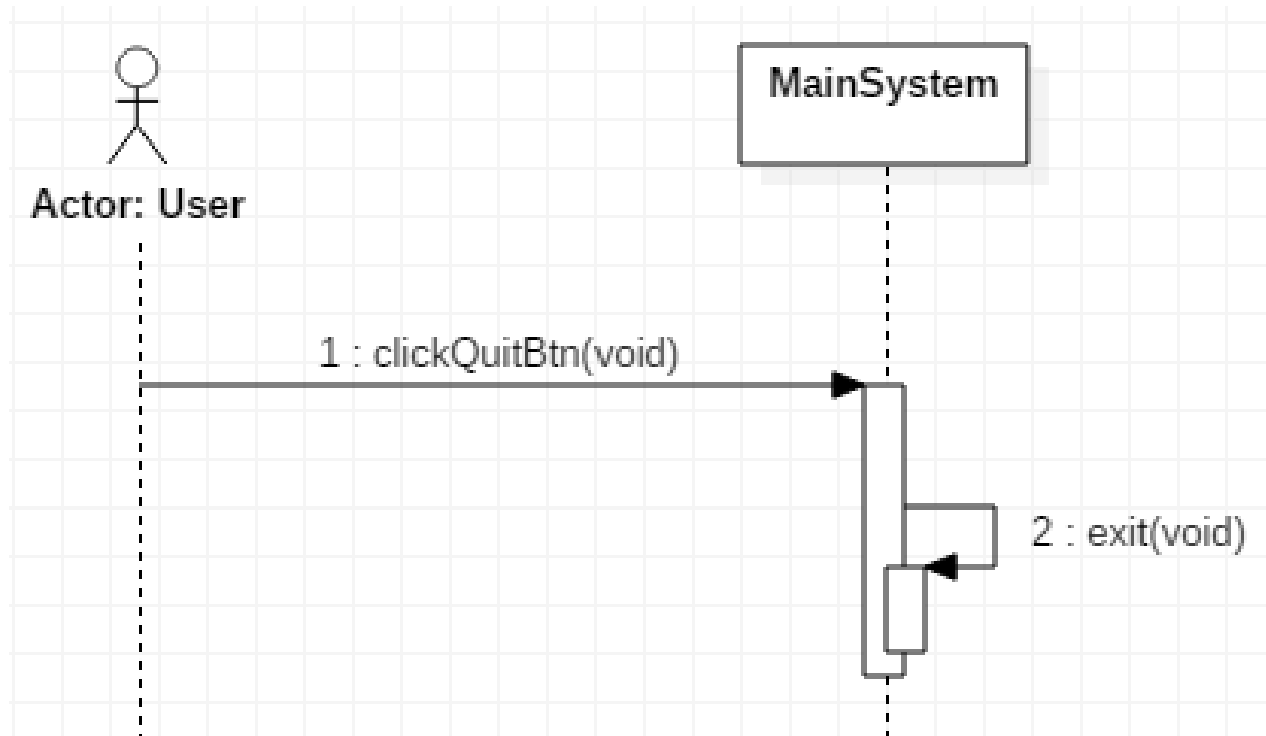



[setCategory]

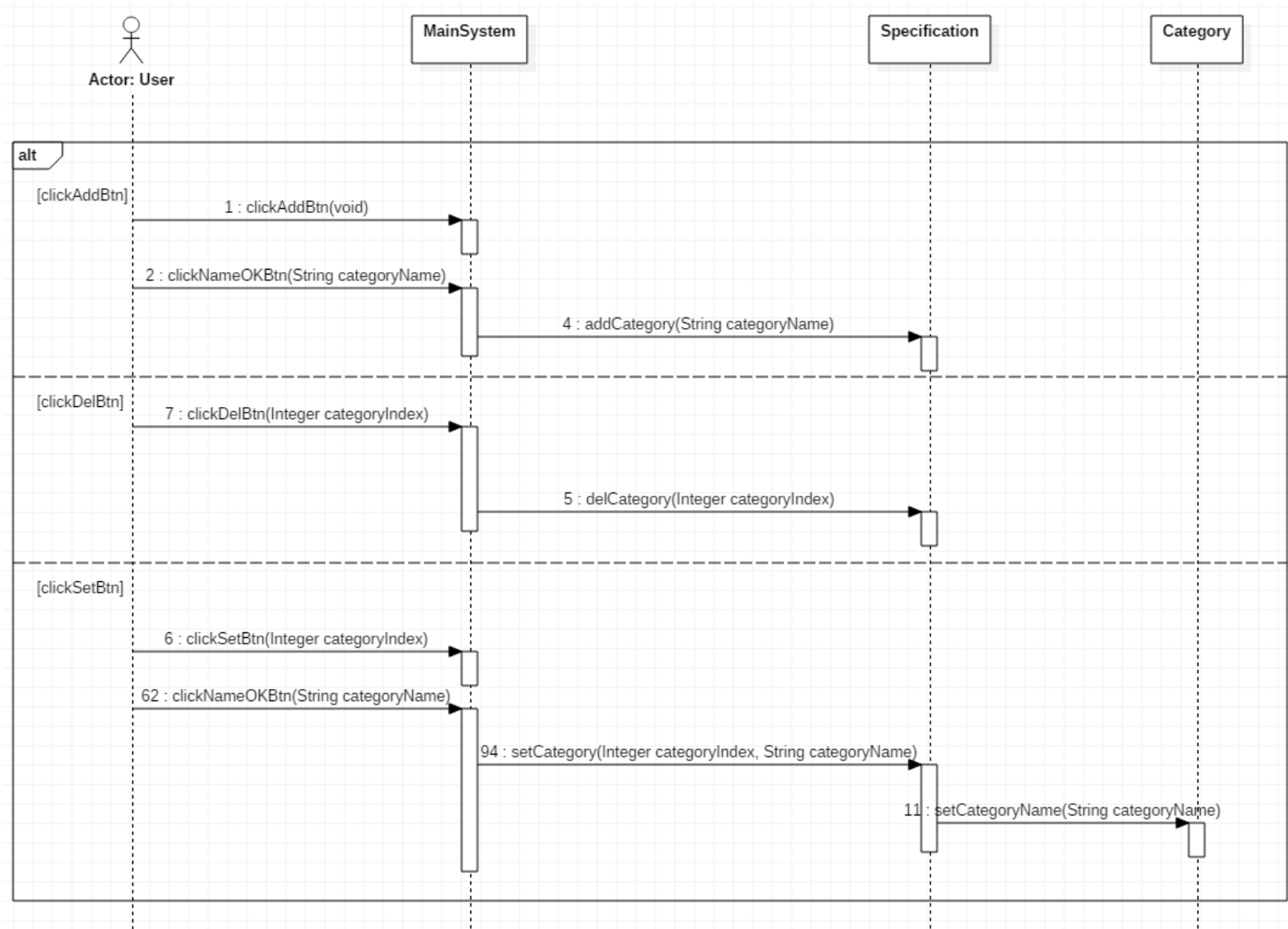

[setRepresentativeValue]

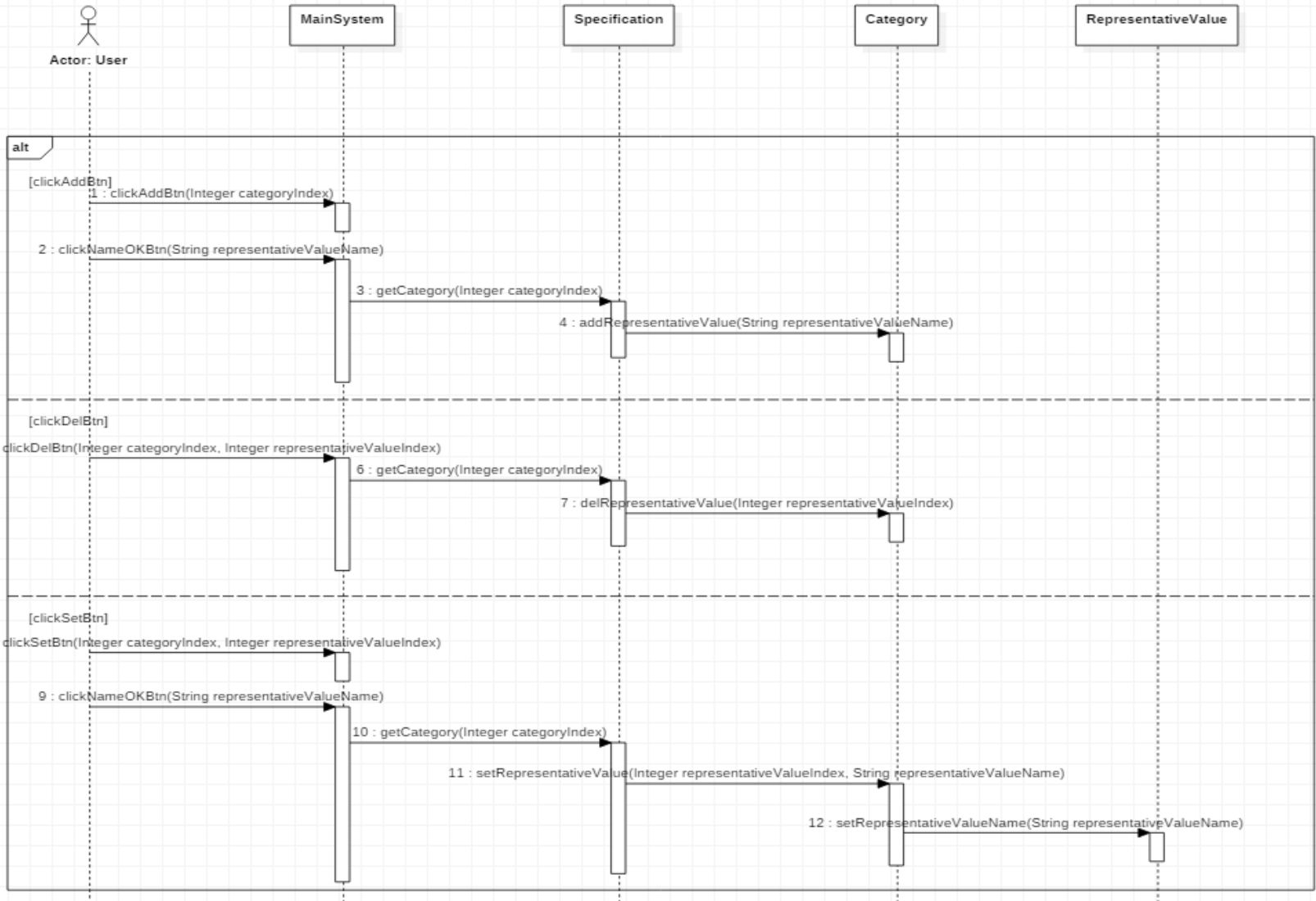



[setProperty]

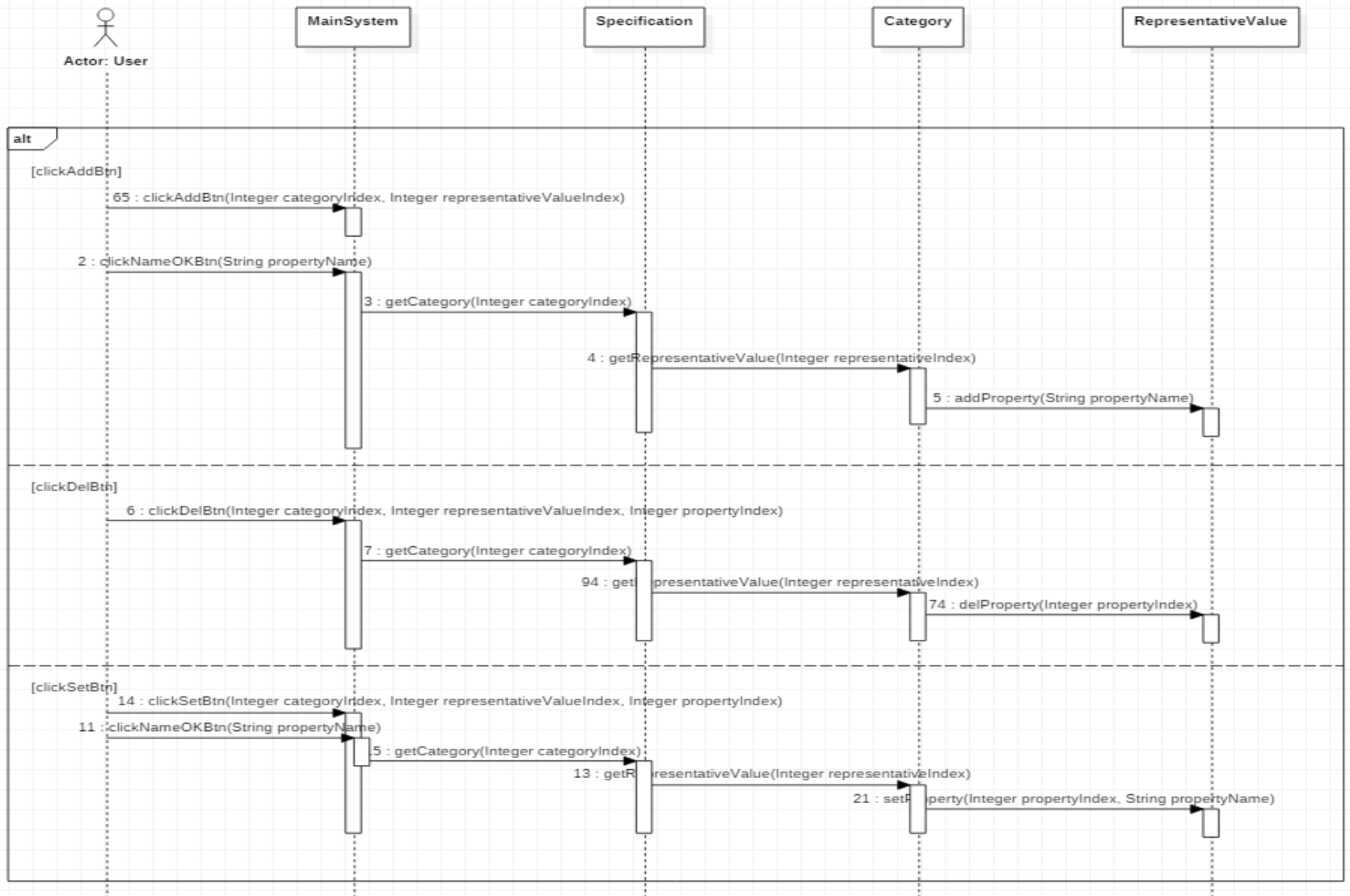



[setIfProperty]

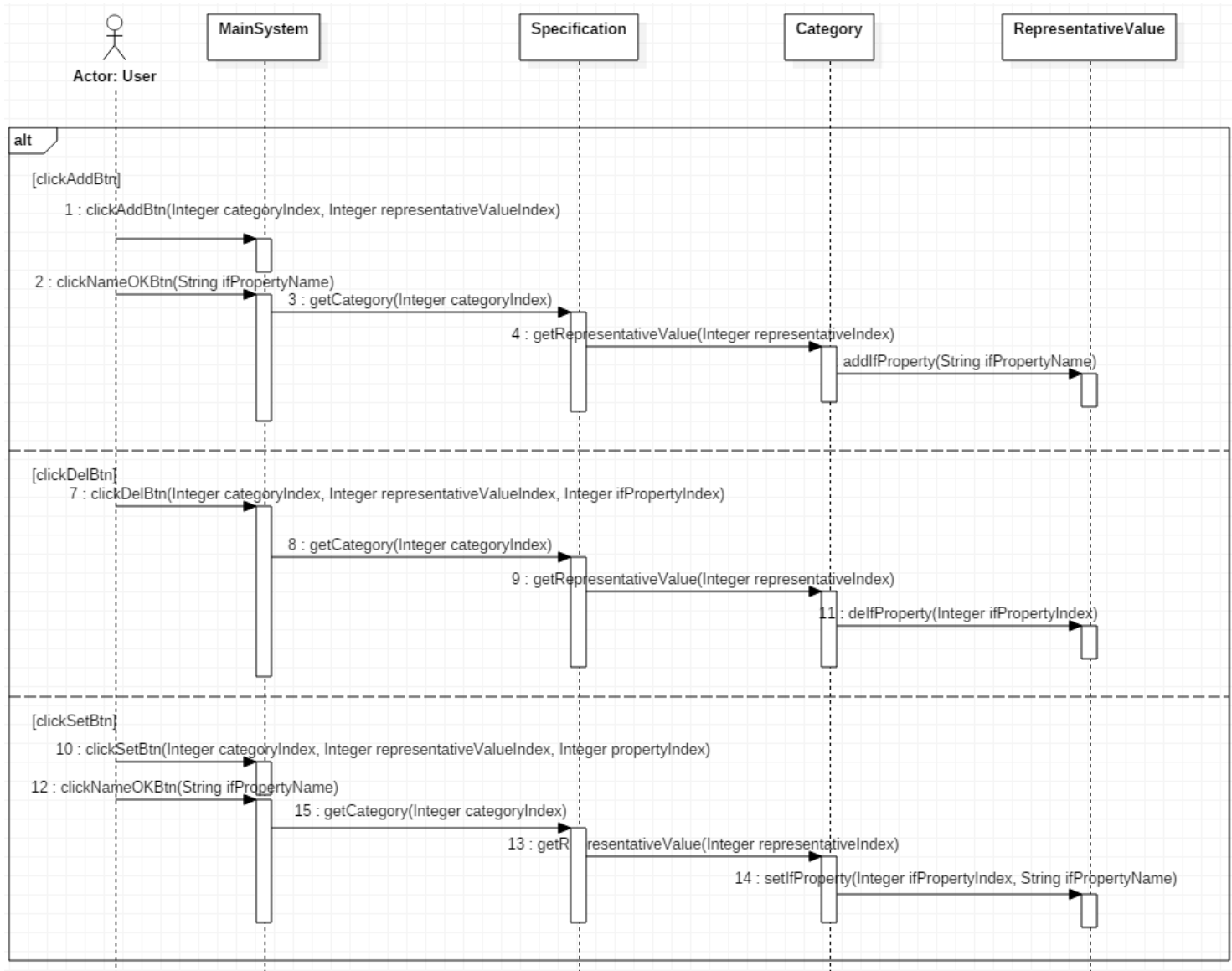



[setSingleError]

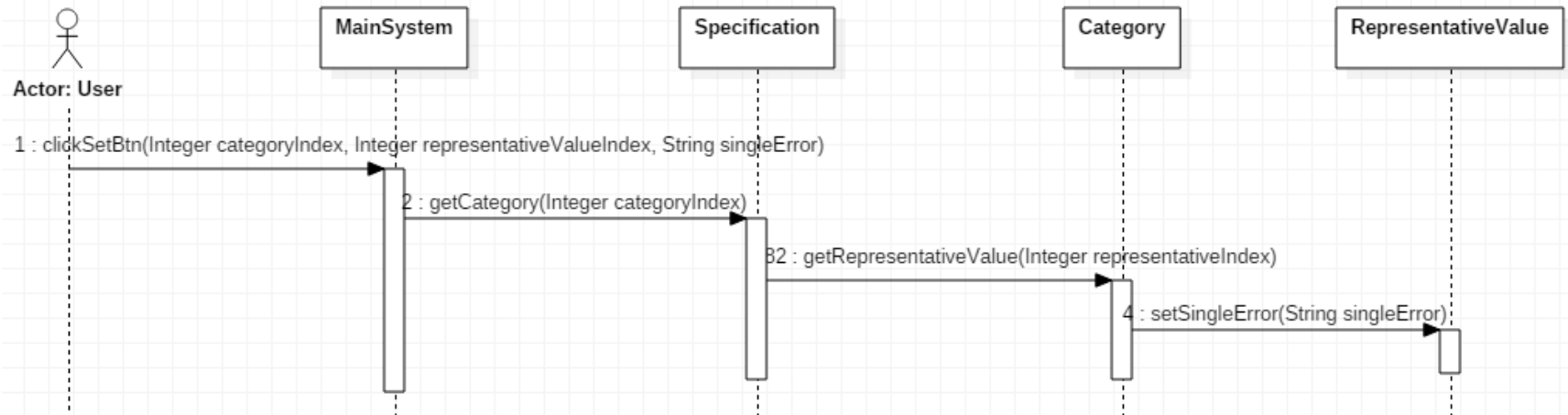



[setPriorityRank]

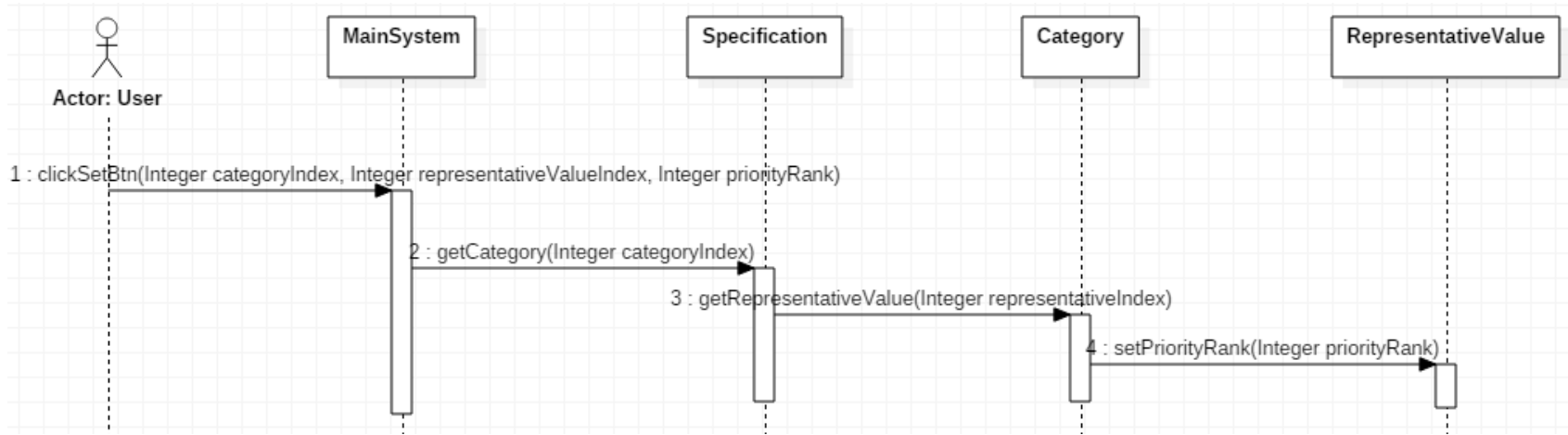

[generateTestCase]

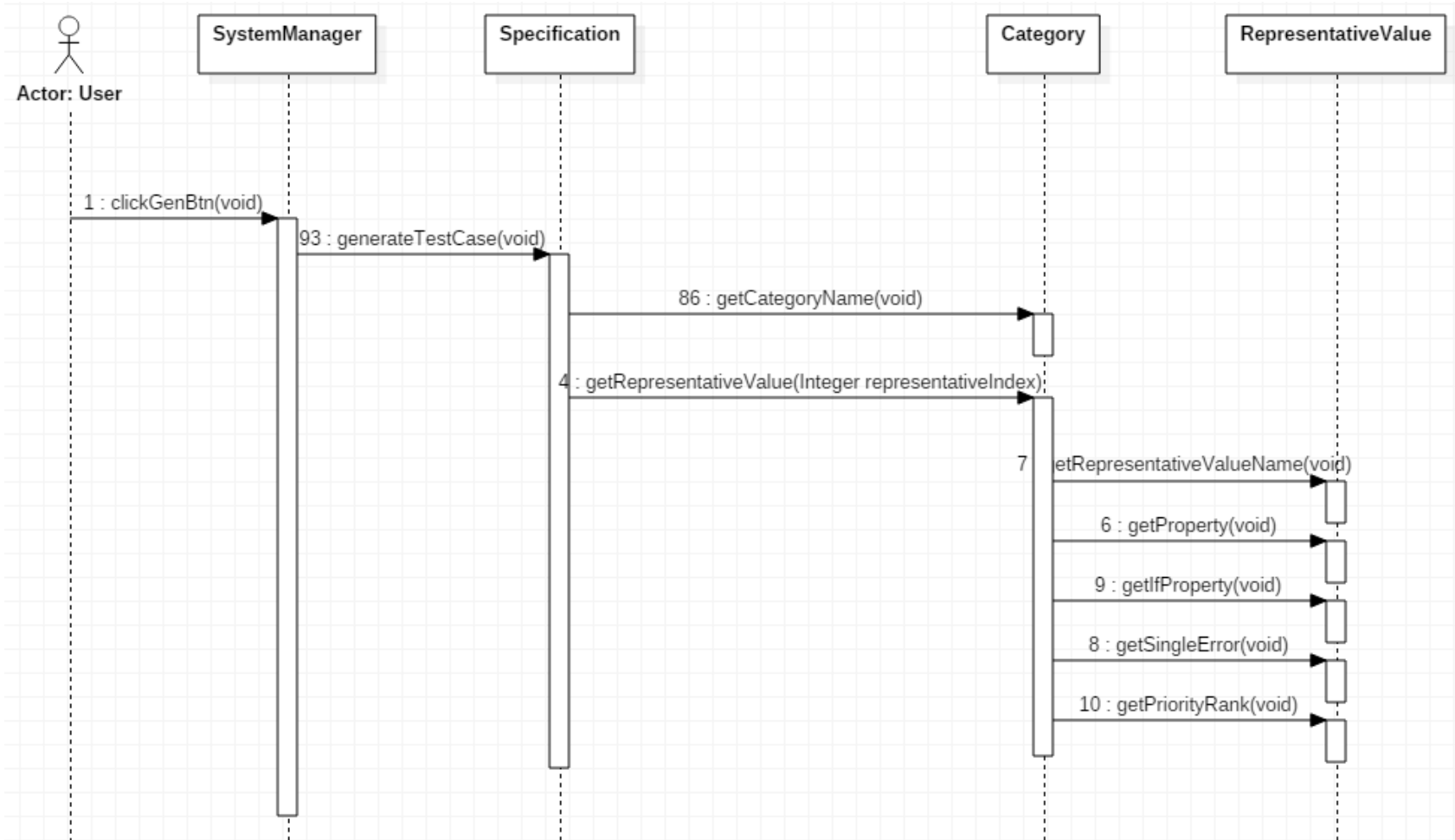



[export2excel]

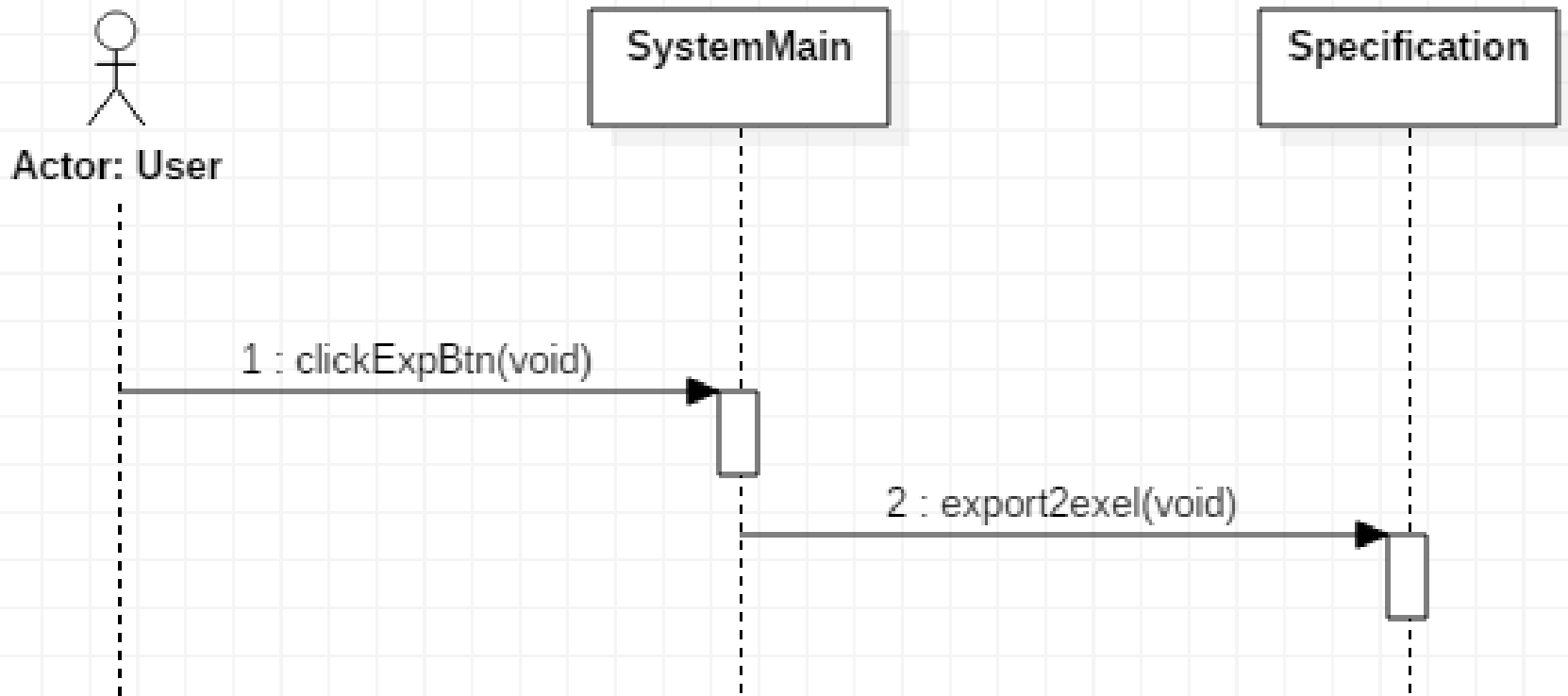



[saveSpecification]

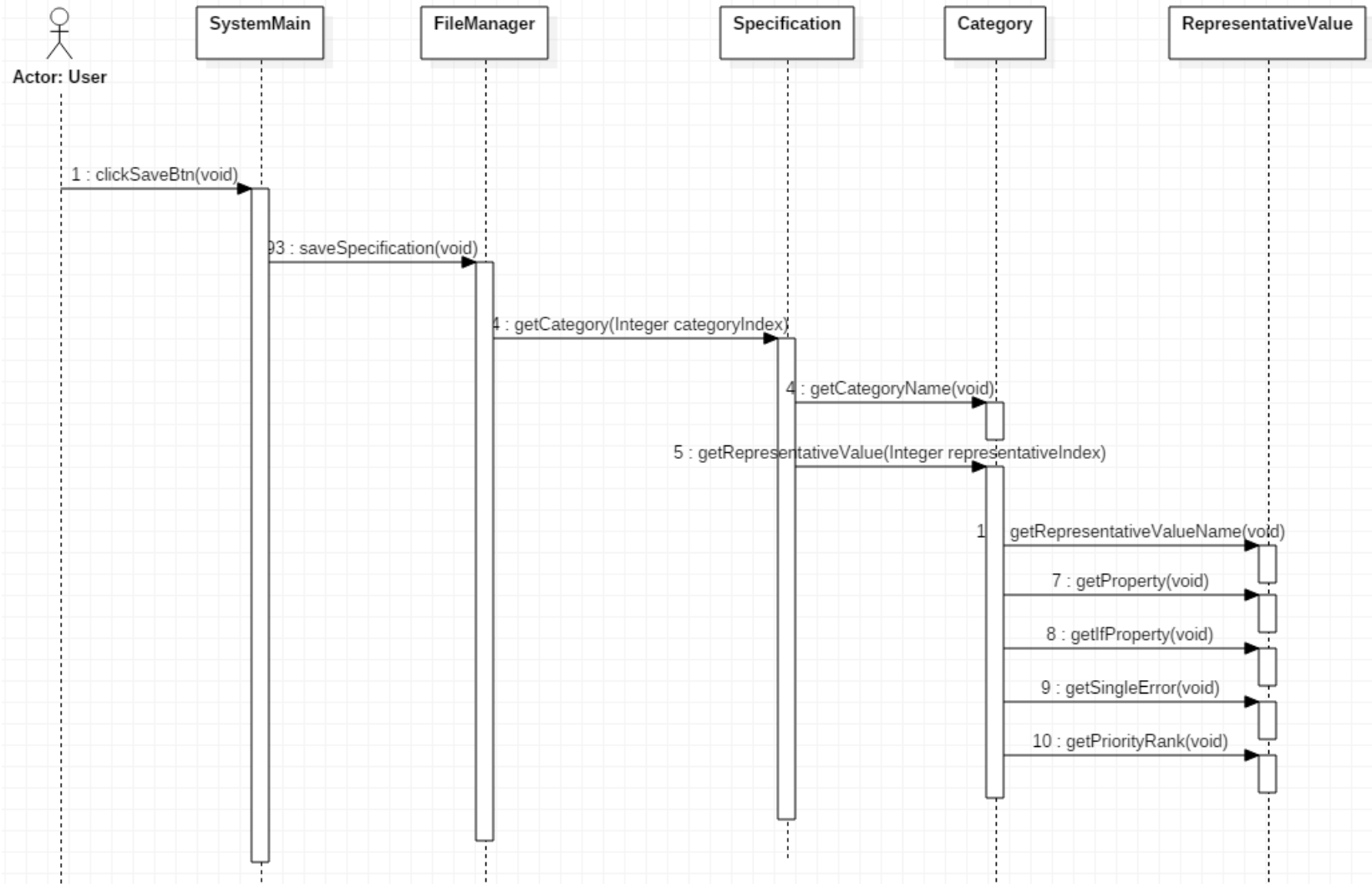



6.

Define Design Class Diagrams



6. Define Design Class Diagrams

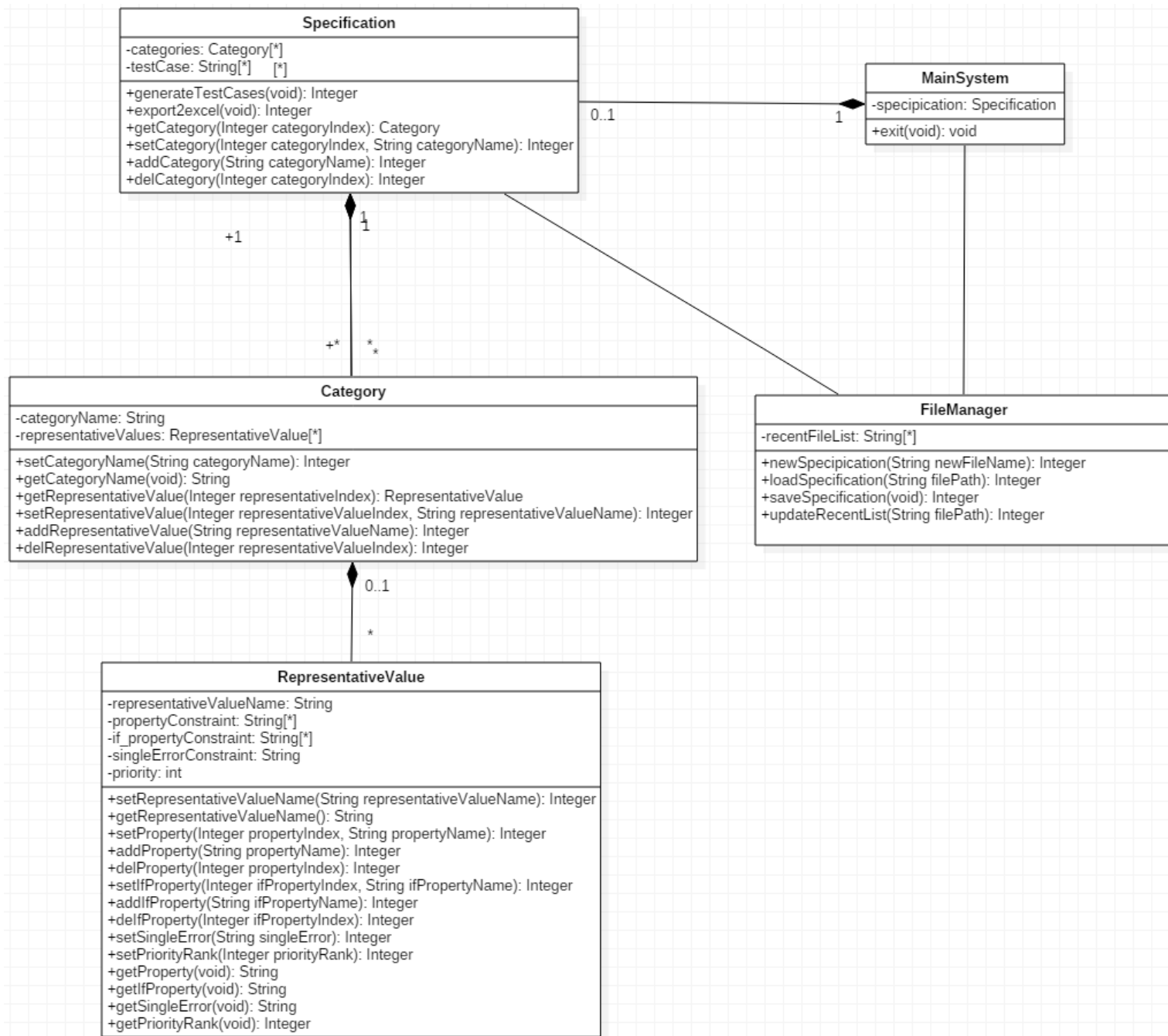



7.

Design Traceability Analysis



7. Design Traceability Analysis

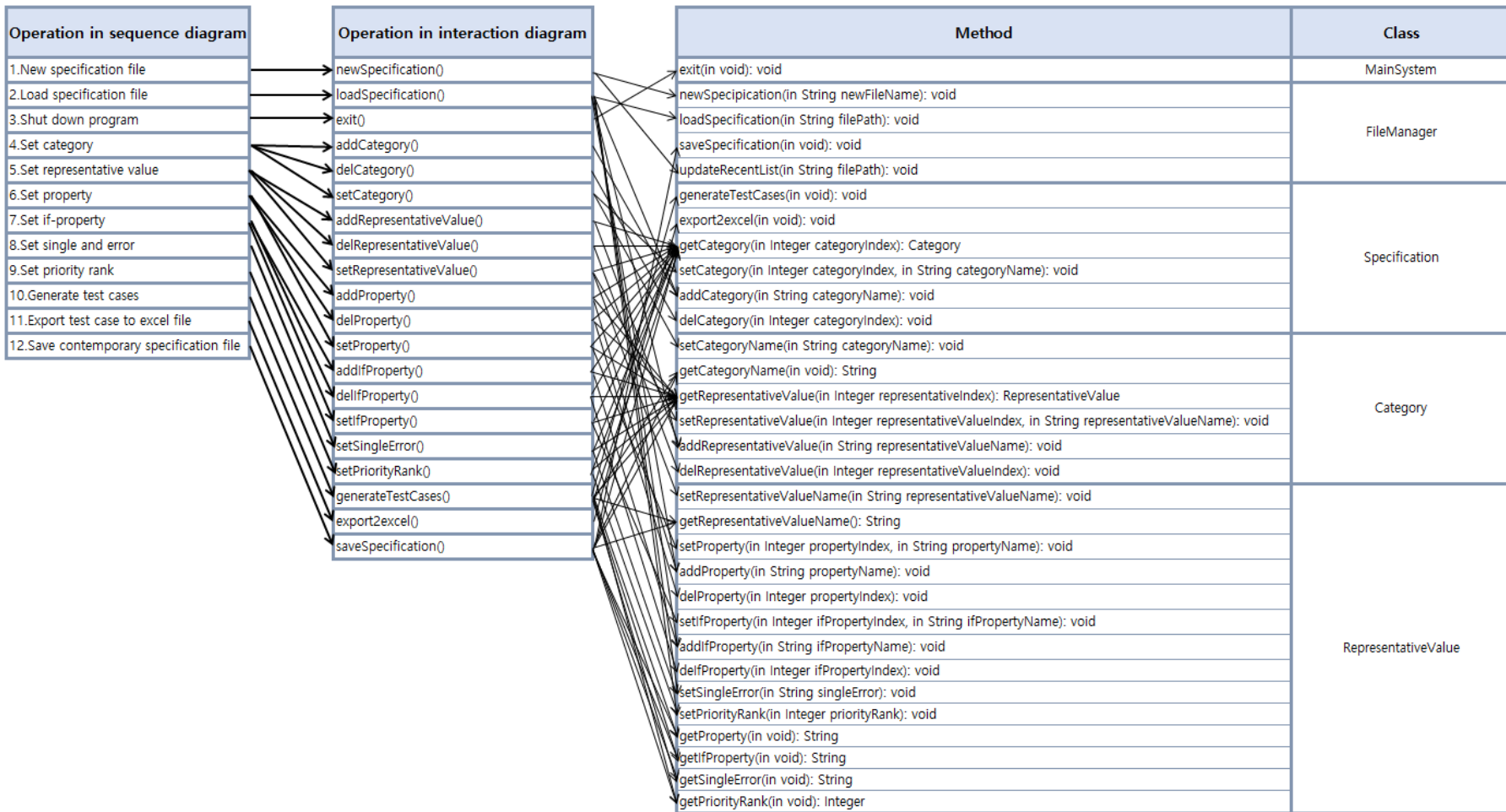

Q & A





Thank you!