Feedback Category Partitioning Test Tool

201311272 나경수
201311300 이원재
201311306 이진호
201310672 한석호

목차

CONTENTS

Modified Part

Activity2051. Implement Class & Method Definitions

Activity2052. Implement Windows

Activity2055. Write Unit Test Code

Activity2061. Unit Testing

Activity2063. System Testing

Activity2067. Testing Traceability Analysis

Modified Part

2040 Sequence Diagram

2040_ver1	2040_ver2
USE CASE SendProject + RecvProject SendFeedback + RecvFeedback	USE CASE SendProject SendFeedback

Modified Part

2040 Sequence Diagram

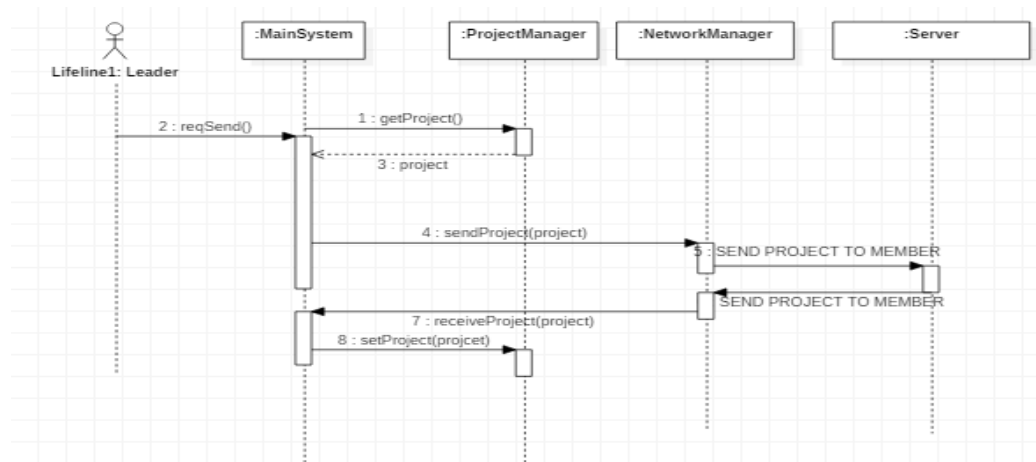
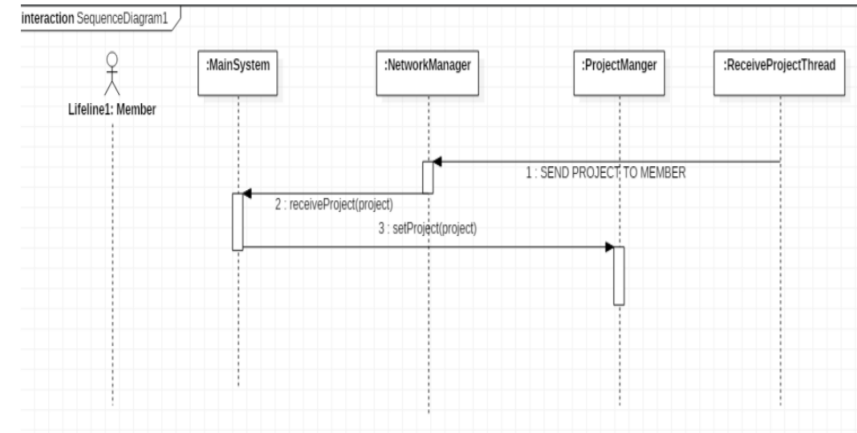
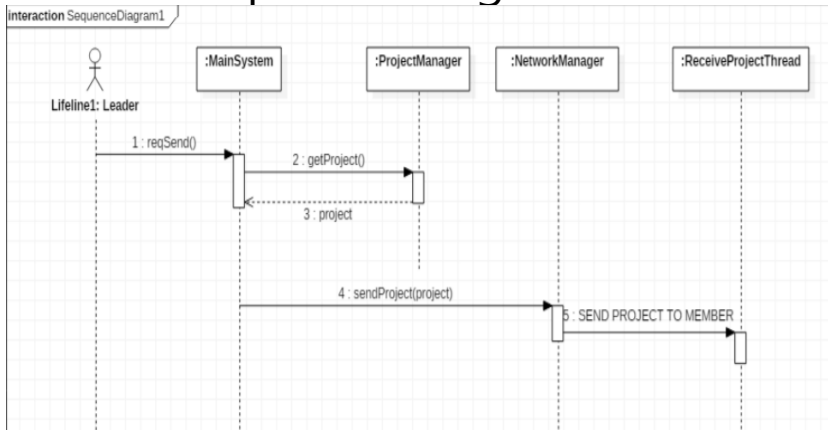

Modified Part

2040 Sequence Diagram

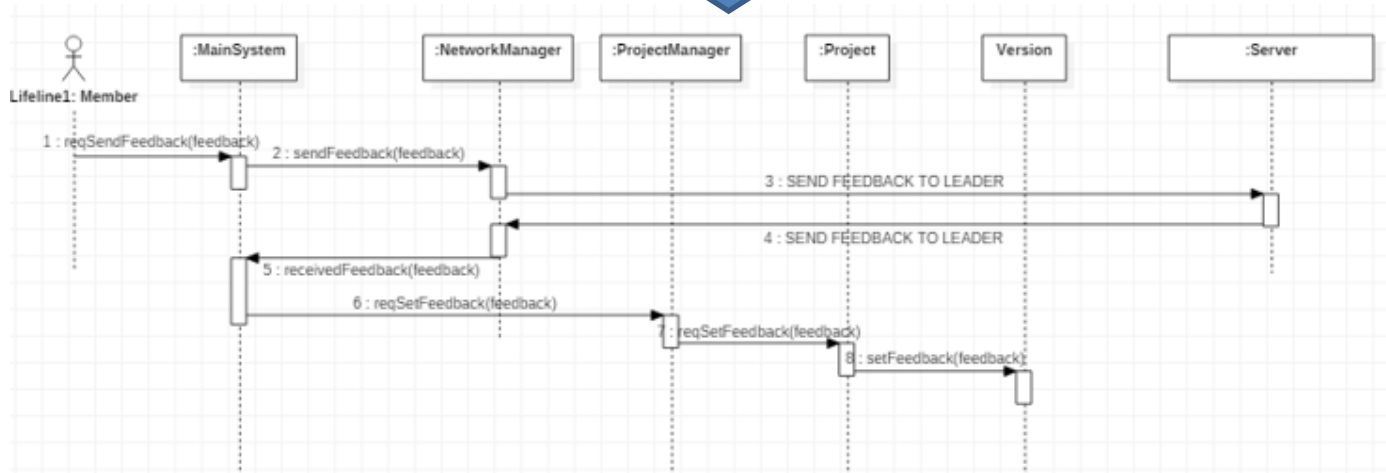
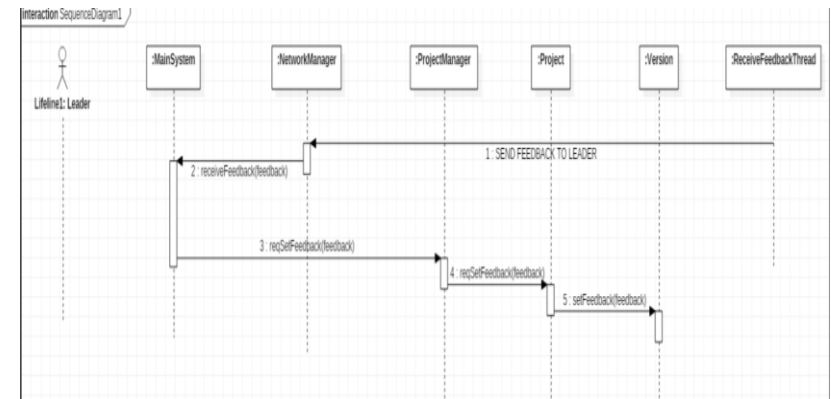
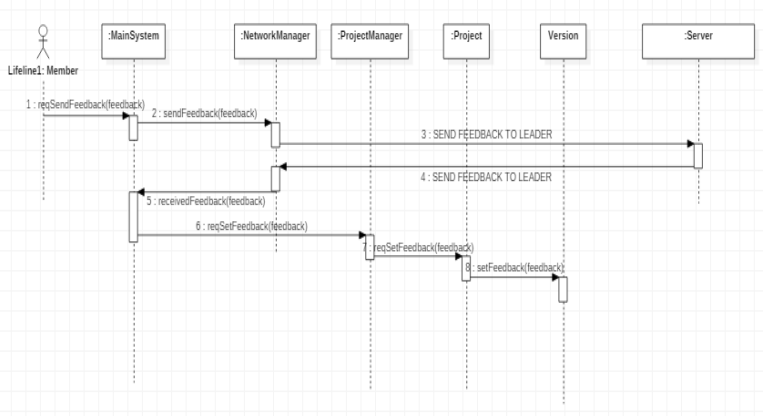

Modified Part

2040 Class Diagram
Class ProjectManager

2040_ver1	2040_ver2
<p>변경 전</p> <p>createCategory() createRPValue() createConstraints()</p> <p>제거</p> <p>serialize() Class – ProjectManager</p>	<p>변경 후</p> <p>reqCreateCategory() reqCreateRPValue() reqCreateConstraints()</p> <p>추가</p> <p>reqAddVersion()</p>

Modified Part

2040 Class Diagram
Class Category

2040_ver1	2040_ver2
	추가 categoryName: String RPValue: RepresentativeValue consCount: int rpListIndex propertyNum: int

Modified Part

2040 Class Diagram
Class RepresentativeValue

2040_ver1	2040_ver2
	추가 constraintsNum: int RPValueName: String propertyNum: int createConstraintsName(in String constraintsName): void

Modified Part

2040 Class Diagram
Class NetworkManager

2040_ver1	2040_ver2
변경전 sendProject(file)	변경 후 sendProject()
제거 reqReceivedFile() reqRecevedFeedback()	추가 socket: Socket name: String

Activity2051. Implement Class & Method Definitions

Type	Class
Name	MainSystem
Purpose	UI와 model간의 데이터 교환을 맡는다. 다른 기능들을 전체적으로 지원한다.
Overview	N/A
Cross Reference	Login, CreateProject, OpenProject, saveProject, addVersion, sendProject, combinationTest case, showVersion, sendFeedback, calcualteTestCaseNum, receiveFeedback, receiveProject
Exceptional Course of Event	N/A

Type	Class
Name	NetworkManager
Purpose	Leader 와 Member에서 프로젝트와 피드백을 주고 받기 위해서 서버에 해당 내용을 전송 시키고 서버로부터 프로젝트 또는 피드백을 받기 위한 클래스
Overview	N/A
Cross Reference	SendProject, ReceiveProject, SendFeedback, Receive Feedback
Exceptional Course of Event	서버가 실행 되고 있어야 한다.

Activity2051. Implement Class & Method Definitions

Type	Class
Name	ReceiveThreadInMainServer
Purpose	Leader의 프로젝트를 Member에게 전송 및 Member의 feedback을 Leader에게 전송
Overview	N/A
Cross Reference	SendProject, ReceiveProject, SendFeedback, Receive Feedback
Exceptional Course of Event	클라이언트 중 하나가 종료되면 클라이언트의 소켓을 닫고, ArrayList에서 제거 시켜준다.

Type	Class
Name	ReceiveThreadInNetworkManager
Purpose	프로젝트 또는 피드백을 메인 시스템에 전달
Overview	N/A
Cross Reference	SendProject, ReceiveProject, SendFeedback, Receive Feedback
Exceptional Course of Event	서버가 실행 되고 있어야 한다.

Activity2051. Implement Class & Method Definitions

Type	Class
Name	MainServer
Purpose	클라이언트 로그인 요청 처리 및 ReceiveThreadInMainServer 스레드 실행
Overview	N/A
Cross Reference	SendProject, ReceiveProject, SendFeedback, Receive Feedback
Exceptional Course of Event	N/A

Type	Class
Name	ResultManager
Purpose	프로젝트의 데이터를 이용 테스트 케이스 개수 및 테스트 케이스 산출.
Overview	N/A
Cross Reference	combinationTestcase, calculalteTestCaseNum,
Exceptional Course of Event	프로젝트가 존재 해야 한다.

Activity2051. Implement Class & Method Definitions

Type	Class
Name	ProjectManager
Purpose	프로젝트의 생성하며 데이터를 관리한다.
Overview	N/A
Cross Reference	CreateProject, OpenProject, saveProject, addVersion, sendProject, combinationTestcase, showVersion, sendFeedback, calcualteTestCaseNum, receiveFeedback, receiveProject
Exceptional Course of Event	N/A

Type	Class
Name	Project
Purpose	Version들을 가지며 버전 데이터의 생성에 관여한다.
Overview	N/A
Cross Reference	CreateProject, OpenProject, saveProject, addVersion, sendProject, receiveProject
Exceptional Course of Event	N/A

Activity2051. Implement Class & Method Definitions

Type	Class
Name	Version
Purpose	Category들을 가지며 Category 데이터 생성에 관여한다.
Overview	N/A
Cross Reference	CreateProject, OpenProject, saveProject, addVersion, sendProject, receiveProject
Exceptional Course of Event	N/A

Type	Class
Name	Category
Purpose	RrepresentativeValue들을 가지며 RrepresentativeValue 데이터 생성에 관여한다.
Overview	N/A
Cross Reference	CreateProject, OpenProject, saveProject, addVersion, sendProject, receiveProject
Exceptional Course of Event	N/A

Activity2051. Implement Class & Method Definitions

Type	Class
Name	ReprentativeValue
Purpose	Constraints 들을 가지며 Constraints 데이터 생성에 관여한다.
Overview	N/A
Cross Reference	CreateProject, OpenProject, saveProject, add Version, sendProject, receiveProject
Exceptional Course of Event	N/A

Activity2051. Implement Class & Method Definitions

Type	Method
Name	loginCheck
Purpose	클라이언트의 로그인 요청 처리 후 성공여부 전송
Overview	N/A
Cross Reference	SendProject, ReceiveProject, SendFeedback, Receive Feedback
Input	id : int
Output	boolean
Abstract Operation	로그인체크 진행 후 클라이언트에게 성공 여부 전송
Exceptional Course of Event	Leader가 이미 있다면 로그인에 실패한다.

Type	Method
Name	reqLogin
Purpose	서버에 로그인 요청
Overview	N/A
Cross Reference	SendProject, ReceiveProject, SendFeedback, Receive Feedback
Input	id : int
Output	boolean
Abstract Operation	<ol style="list-style-type: none"> 1. 서버에 id를 전송하여 로그인을 요청한다. 2. 로그인에 성공하면 서버에서 데이터를 받기위한 스레드를 실행 시킨다.
Exceptional Course of Event	서버가 실행되고 있어야 한다.

Activity2051. Implement Class & Method Definitions

Type	Method
Name	sendProject
Purpose	서버에 프로젝트 전송
Overview	N/A
Cross Reference	SendProject, ReceiveProject, SendFeedback, Receive Feedback
Input	project : Object
Output	void
Abstract Operation	1. 서버에 Project 객체를 전송한다.
Exceptional Course of Event	서버가 실행되고 있어야 한다.

Type	Method
Name	run
Purpose	프로젝트 및 피드백을 클라이언트에게 전달
Overview	In ReceiveThreadInMainserver
Cross Reference	SendProject, ReceiveProject, SendFeedback, Receive Feedback
Input	void
Output	void
Abstract Operation	1. 로그인을 실행한다 2. 프로젝트를 받으면 멤버들에게 전송한다. 3. 피드백을 보내면 리더에게 전송한다.
Exceptional Course of Event	N/A

Activity2051. Implement Class & Method Definitions

Type	Method
Name	sendFeedback
Purpose	서버에 피드백 전송
Overview	N/A
Cross Reference	SendProject, ReceiveProject, SendFeedback, Receive Feedback
Input	feedback : String
Output	void
Abstract Operation	1. 서버에 피드백 문자열을 전송한다.
Exceptional Course of Event	서버가 실행되고 있어야 한다.

Type	Method
Name	run
Purpose	프로젝트 및 피드백을 메인 시스템에 전달
Overview	In ReceiveThreadInNetworkManager
Cross Reference	SendProject, ReceiveProject, SendFeedback, Receive Feedback
Input	void
Output	void
Abstract Operation	1. 로그인을 실행한다 2. 피드백을 받으면 메인 시스템에 전달한다 3. 프로젝트를 받으면 메인 시스템에 전달한다.
Exceptional Course of Event	N/A

Activity2051. Implement Class & Method Definitions

Type	Method
Name	createProject
Purpose	프로젝트 생성 및 이름 설정
Overview	N/A
Cross Reference	SendProject, ReceiveProject, SendFeedback, Receive Feedback
Input	projectName : String , categoryNum : int
Output	void
Abstract Operation	<ol style="list-style-type: none"> 1. 프로젝트를 생성한다 2. 프로젝트의 이름을 set 한다.
Exceptional Course of Event	N/A

Type	Method
Name	createCategory
Purpose	카테고리 객체를 생성
Overview	N/A
Cross Reference	SendProject, ReceiveProject, SendFeedback, Receive Feedback
Input	categoryName : String , RPValueNum : int
Output	void
Abstract Operation	<ol style="list-style-type: none"> 1. 카테고리를 생성 후 리스트에 추가한다. 2. 프로젝트의 이름을 set 한다.
Exceptional Course of Event	N/A

Activity2051. Implement Class & Method Definitions

Type	Method
Name	createRPValue
Purpose	RPValue 객체를 생성
Overview	N/A
Cross Reference	CreateProject, addVersion, sendProject, receive Project
Input	RPValueName : String , constraintNum : int
Output	void
Abstract Operation	1. Representative Value생성을 요청한다. .
Exceptional Course of Event	N/A

Type	Method
Name	createConstraints
Purpose	RPValue 객체의 리스트에 constraints 추가
Overview	N/A
Cross Reference	CreateProject, addVersion, sendProject, receive Project
Input	constraintName : String
Output	void
Abstract Operation	1. Constraints생성을 요청한다. .
Exceptional Course of Event	N/A

Activity2051. Implement Class & Method Definitions

Type	Method
Name	calculateTestCaseNum
Purpose	테스트케이스 개수 계산
Overview	N/A
Cross Reference	CalculateTestCaseNum
Input	version : Version
Output	int
Abstract Operation	1. 테스트 케이스의 개수를 계산한다.
Exceptional Course of Event	N/A

Type	Method
Name	combinationTestCase
Purpose	테스트케이스 산출
Overview	N/A
Cross Reference	combinationTestCase
Input	version : Version
Output	int
Abstract Operation	1. 테스트케이스를 파일로 저장한다.
Exceptional Course of Event	N/A

Activity2052. Implement Windows

1. Login

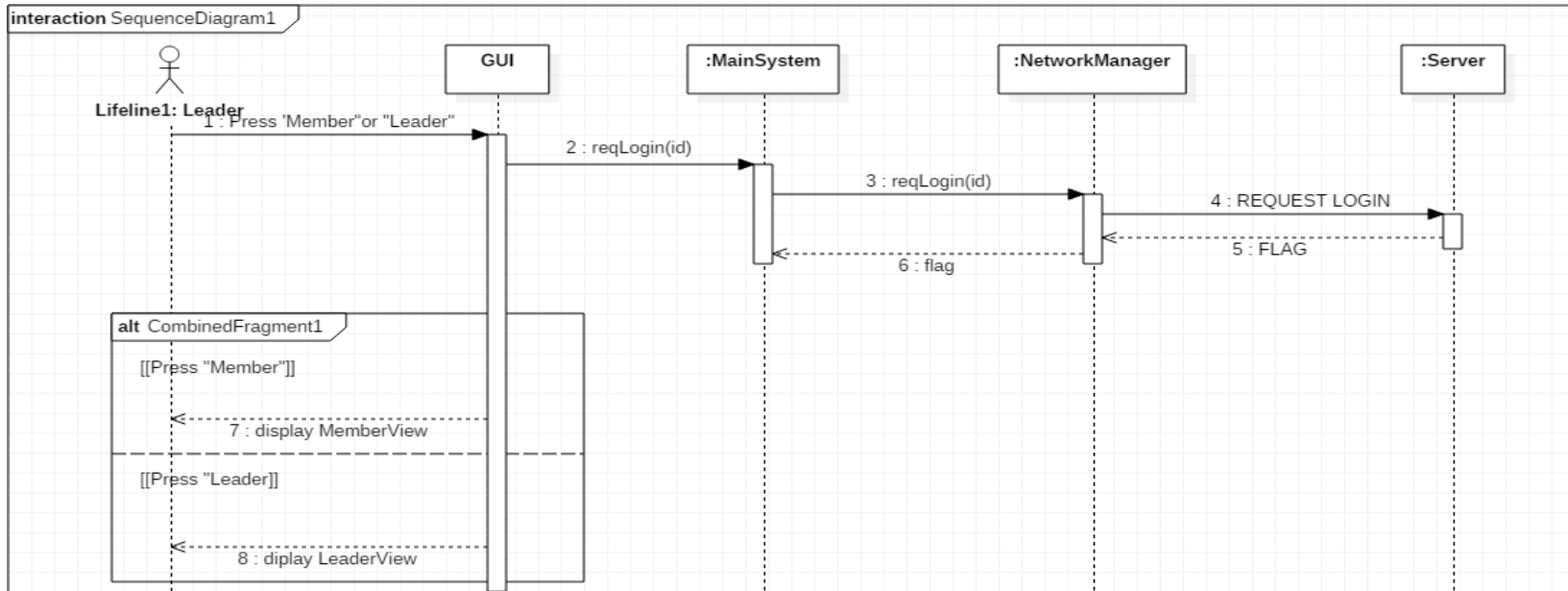

Name	Press "Member", "Leader"
Responsibilities	GUI의 Member, Leader 버튼을 누른다
Type	GUI
Cross Reference	R1
Notes	GUI의 Member, Leader 버튼을 누른다
Pre-Conditions	N/A
Post-Conditions	MemberMain, LeaderMain 창을 화면을 보여준다

Activity2052. Implement Windows

2. New Project

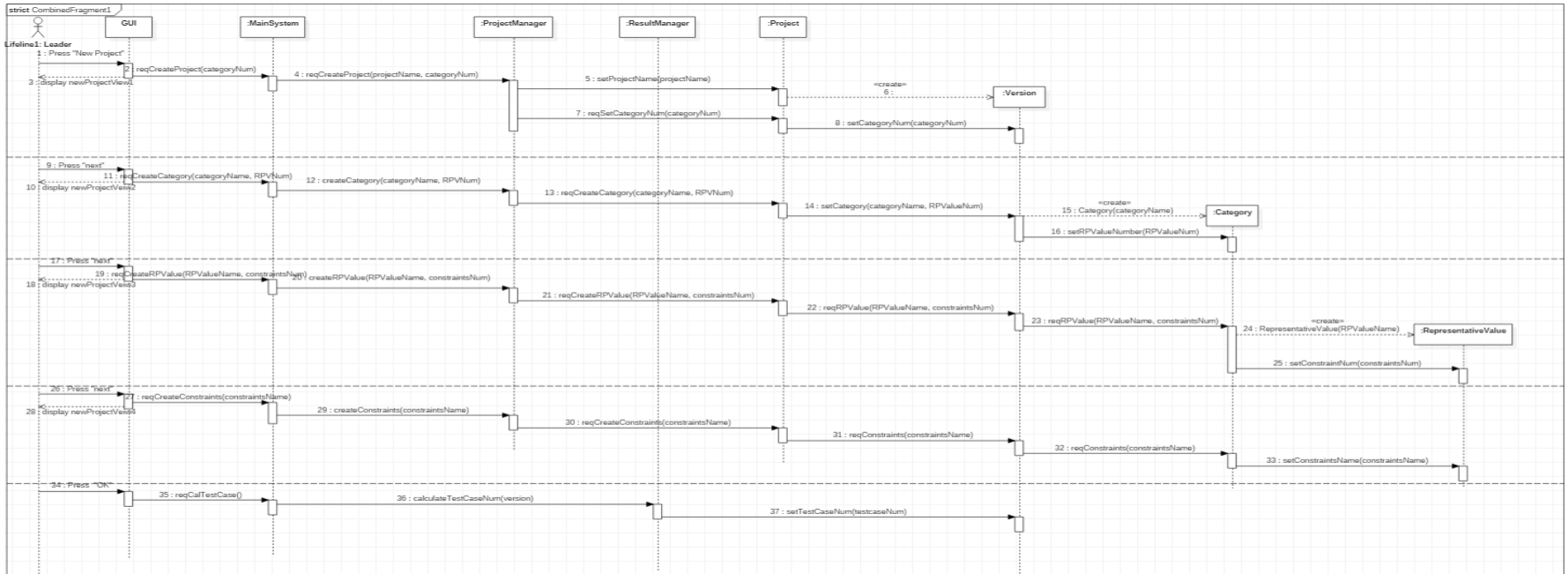

Name	Press "New Proeject"
Responsibilities	GUI의 New Project 버튼을 누른다
Type	GUI
Cross Reference	R2
Notes	GUI의 New Project 버튼을 누른다
Pre-Conditions	N/A
Post-Conditions	NewProjectView1 화면을 보여준다

Activity2052. Implement Windows

2. New Project

Name	Press "next"
Responsibilities	GUI의 next 버튼을 누른다
Type	GUI
Cross Reference	R2
Notes	GUI의 next 버튼을 누른다
Pre-Conditions	N/A
Post-Conditions	NewProjectView2 화면을 보여준다

Name	Press "next"
Responsibilities	GUI의 next 버튼을 누른다
Type	GUI
Cross Reference	R2
Notes	GUI의 next 버튼을 누른다
Pre-Conditions	N/A
Post-Conditions	NewProjectView3 화면을 보여준다

Activity2052. Implement Windows

2. New Project

Name	Press "next"
Responsibilities	GUI의 next 버튼을 누른다.
Type	GUI
Cross Reference	R2
Notes	GUI의 next 버튼을 누른다.
Pre-Conditions	N/A
Post-Conditions	NewProjectView4 창을 화면을 보여준다.

Name	Press "next"
Responsibilities	GUI의 next 버튼을 누른다
Type	GUI
Cross Reference	R2
Notes	GUI의 next 버튼을 누른다
Pre-Conditions	N/A
Post-Conditions	NewProjectView4 창을 닫고 프로젝트를 추가한다.

Activity2052. Implement Windows

3. Add Version

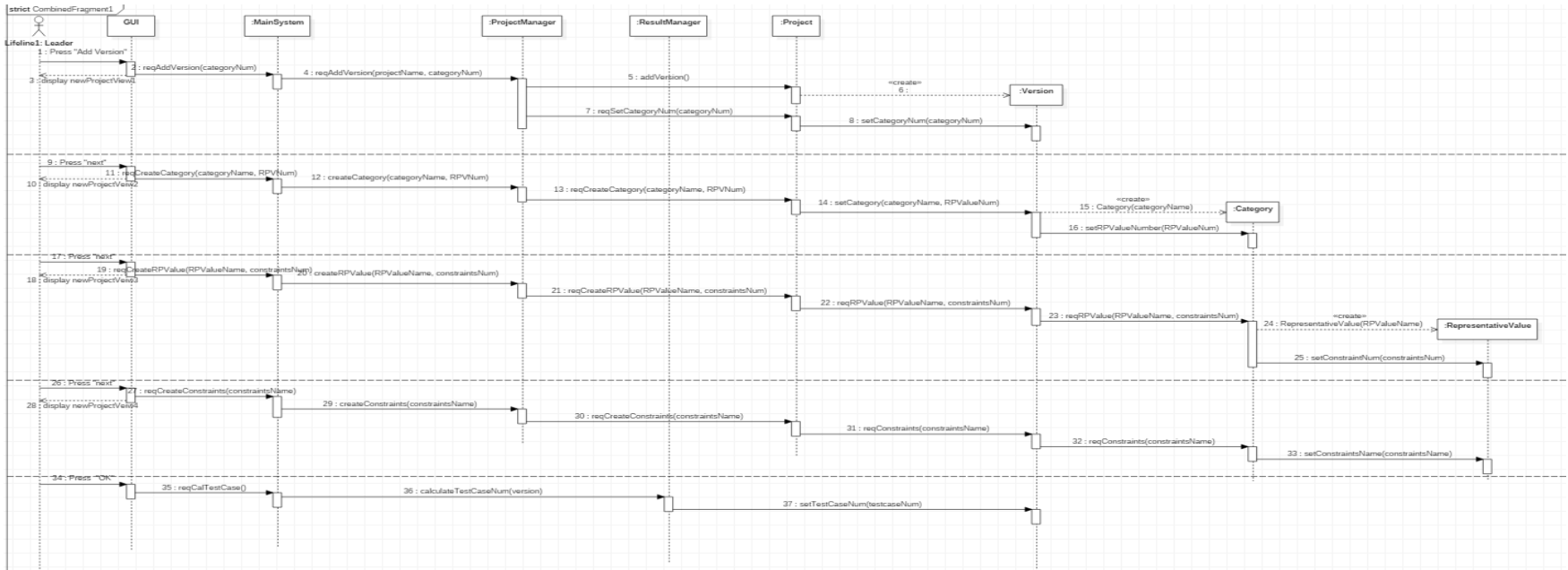

Name	Press "Add Version"
Responsibilities	GUI의 Add Version 버튼을 누른다
Type	GUI
Cross Reference	R5
Notes	GUI의 Add Version 버튼을 누른다
Pre-Conditions	N/A
Post-Conditions	AddVersionView1 화면을 보여준다

Activity2052. Implement Windows

3. Add Version

Name	Press "next"
Responsibilities	GUI의 next 버튼을 누른다
Type	GUI
Cross Reference	R5
Notes	GUI의 next 버튼을 누른다
Pre-Conditions	N/A
Post-Conditions	AddVersionView2 화면을 보여준다

Name	Press "next"
Responsibilities	GUI의 next 버튼을 누른다
Type	GUI
Cross Reference	R5
Notes	GUI의 next 버튼을 누른다
Pre-Conditions	N/A
Post-Conditions	AddVersionView3 화면을 보여준다

Activity2052. Implement Windows

3. Add Version

Name	Press "next"
Responsibilities	GUI의 next 버튼을 누른다.
Type	GUI
Cross Reference	R5
Notes	GUI의 next 버튼을 누른다.
Pre-Conditions	N/A
Post-Conditions	AddVersionView4 창을 화면을 보여준다.

Name	Press "OK"
Responsibilities	GUI의 OK 버튼을 누른다.
Type	GUI
Cross Reference	R5
Notes	GUI의 OK 버튼을 누른다.
Pre-Conditions	N/A
Post-Conditions	AddVersionView4 창을 닫고 현재 프로젝트 안에 버전을 추가한다.

Activity2052. Implement Windows

4. Open Project

interaction SequenceDiagram1

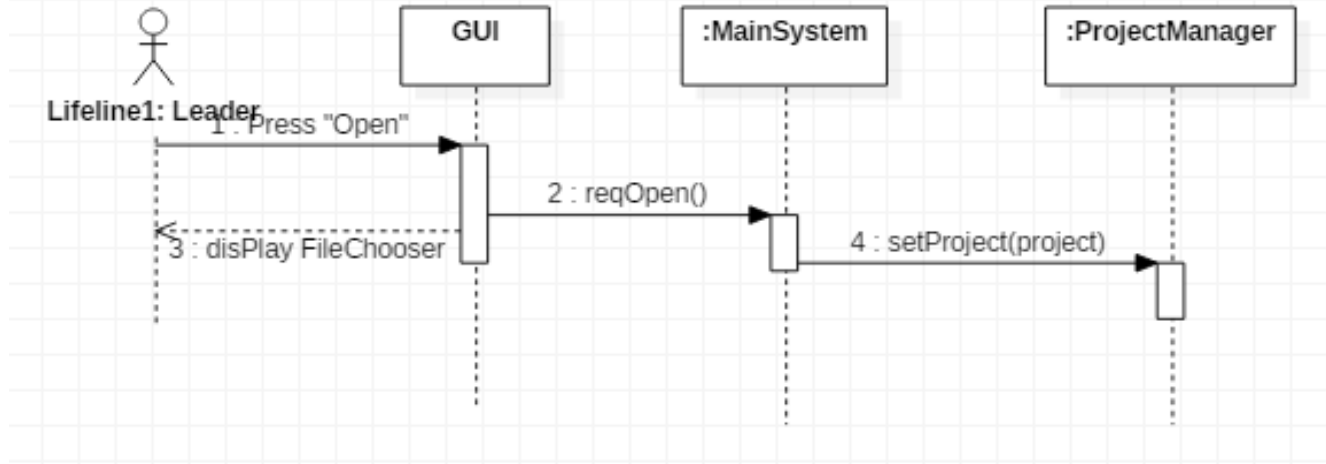

Name	Press "Open"
Responsibilities	GUI의 Open 버튼을 누른다.
Type	GUI
Cross Reference	R3
Notes	GUI의 Open 버튼을 누른다.
Pre-Conditions	N/A
Post-Conditions	FileChooser 창을 화면에 보여준다.

Activity2052. Implement Windows

5. Save Project

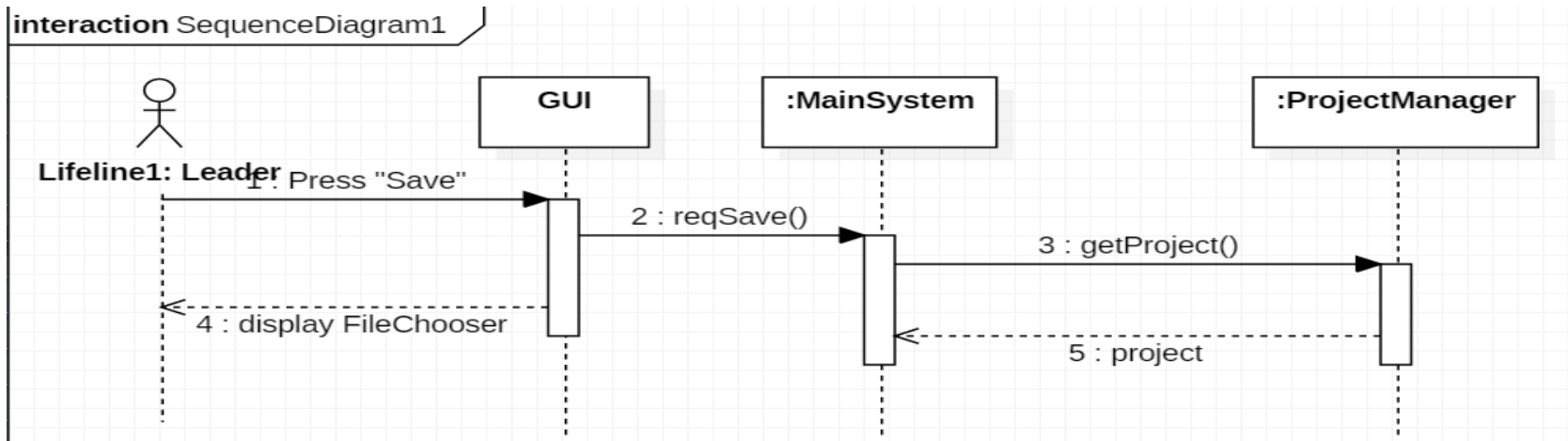

Name	Press "Save"
Responsibilities	GUI의 Save 버튼을 누른다.
Type	GUI
Cross Reference	R4
Notes	GUI의 Save 버튼을 누른다.
Pre-Conditions	N/A
Post-Conditions	FileChooser 창을 화면에 보여준다.

Activity2052. Implement Windows

6. Send Project

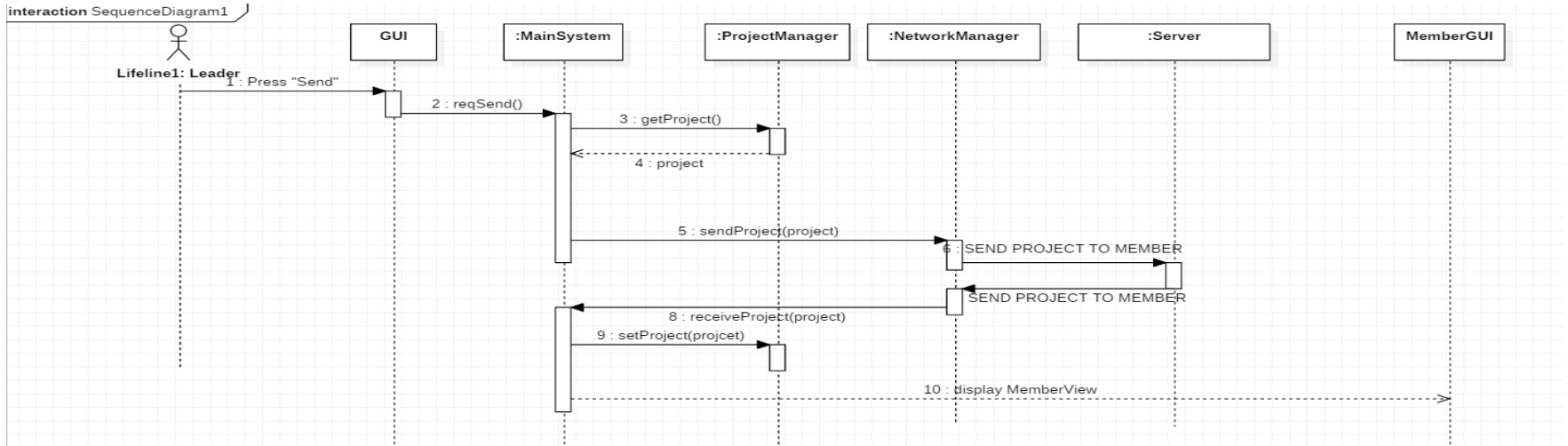

Name	Press "Send"
Responsibilities	GUI의 Send 버튼을 누른다.
Type	GUI
Cross Reference	R6
Notes	GUI의 Send 버튼을 누른다.
Pre-Conditions	N/A
Post-Conditions	멤버에게 프로젝트를 전송낸다.

Activity2052. Implement Windows

7. Show Version

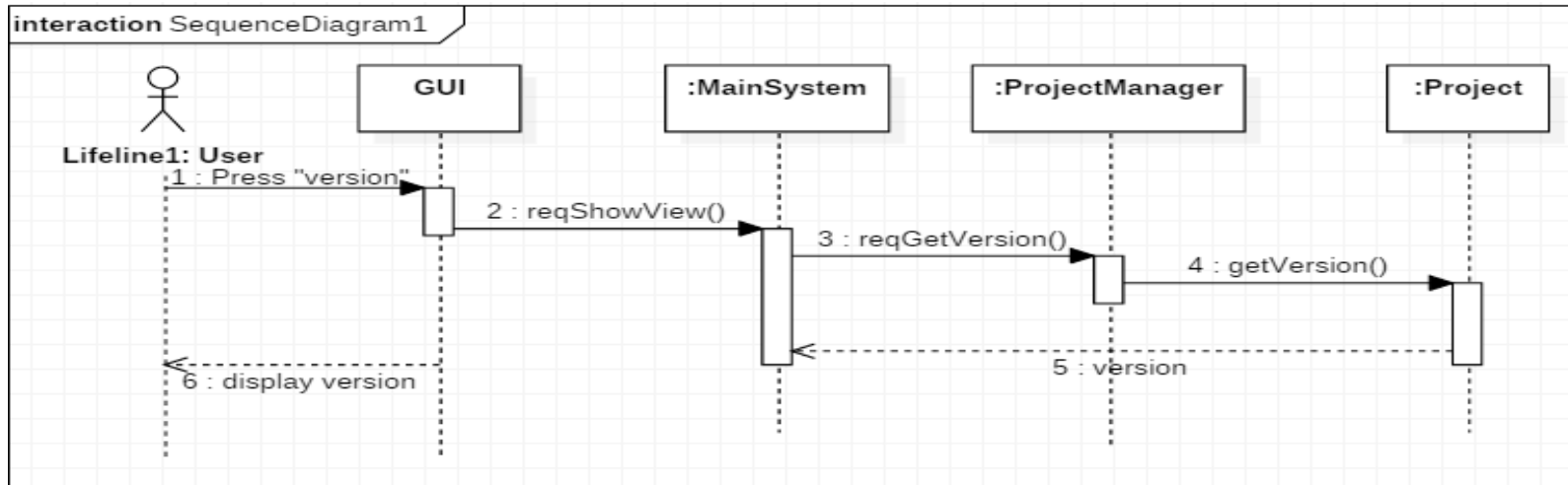

Name	Press "version"
Responsibilities	GUI의 version을 누른다.
Type	GUI
Cross Reference	R8
Notes	GUI의 version을 누른다.
Pre-Conditions	N/A
Post-Conditions	해당 version에 맞는 ShowView화면을 보여준다.

Activity2052. Implement Windows

8. Send Feedback

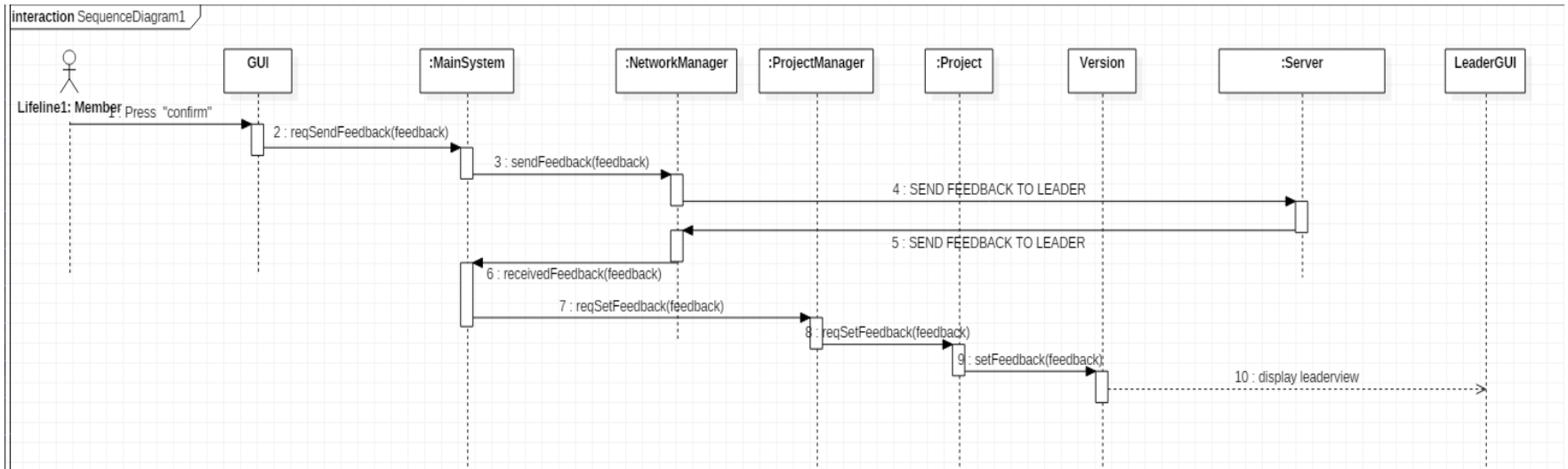

Name	Press "confirm"
Responsibilities	GUI의 Confirm 버튼을 누른다.
Type	GUI
Cross Reference	R9
Notes	GUI의 Confirm 버튼을 누른다.
Pre-Conditions	N/A
Post-Conditions	피드백 입력창에 있는 내용을 리더에게 보내고 피드백 입력 창을 닫는다.

Activity2052. Implement Windows

9. Combination TestCase

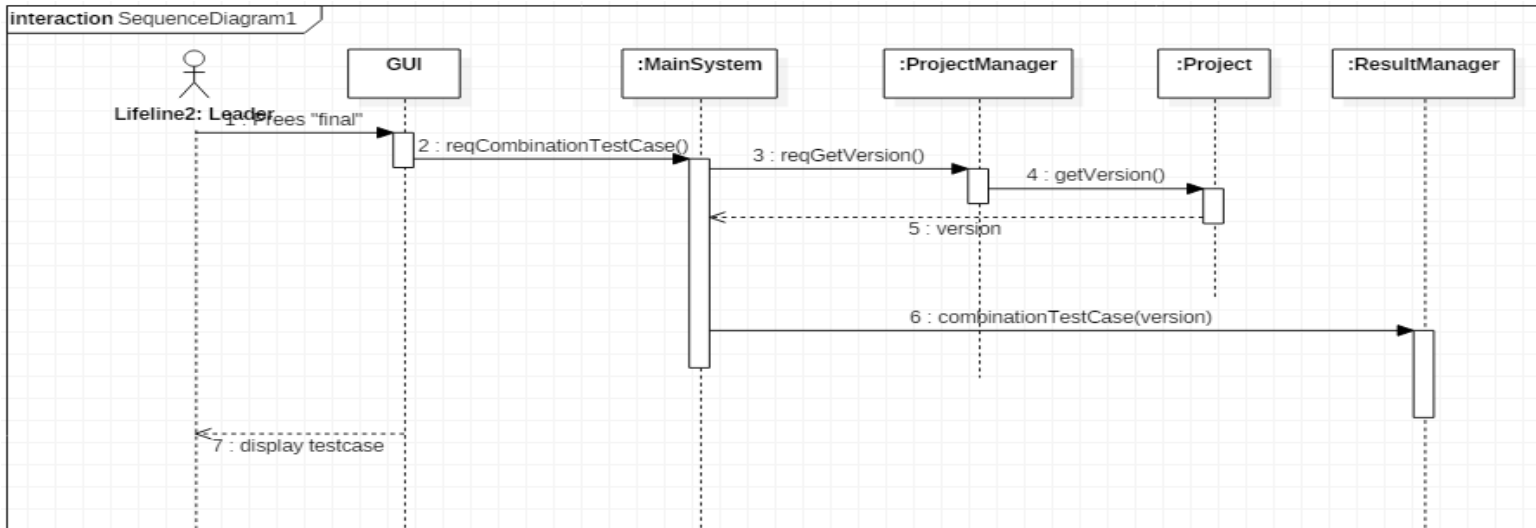

Name	Press "final"
Responsibilities	GUI의 final 버튼을 누른다.
Type	GUI
Cross Reference	R7
Notes	GUI의 final 버튼을 누른다.
Pre-Conditions	N/A
Post-Conditions	TestCase를 조합해서 출력한다.

Activity2055. Write Unit Test Code

Login

```
13
14 public class NetworkManagerTest {
15
16     @Test
17     public void testReqLogin() {
18         //(new MainServer()).startServer();
19         NetworkManager nm ;
20         nm = new NetworkManager();
21         assertTrue("실패", nm.reqLogin(0));
22         nm = new NetworkManager();
23         assertTrue("실패", nm.reqLogin(1));
24         nm = new NetworkManager();
25         assertTrue("실패", !nm.reqLogin(0));
26         nm = new NetworkManager();
27         assertTrue("실패", nm.reqLogin(1));
28         nm = new NetworkManager();
29         assertTrue("실패", nm.reqLogin(1));
30         nm = new NetworkManager();
31         assertTrue("실패", !nm.reqLogin(2));
32         nm = new NetworkManager();
33         assertTrue("실패", !nm.reqLogin(3));
34         nm = new NetworkManager();
35         assertTrue("실패", !nm.reqLogin(4));
36     }
37
38
39 }
```

Activity2055. Write Unit Test Code

calculateTestCaseNum

```
@Test
public void testCalculateTestCaseNum() {
    ms.reqCreateProject("Example 2", 2);

    ms.reqCreateCategory("장애조작", 4);
    ms.reqCreateCategory("시뮬레이션", 2);

    ms.reqCreateRPValue("화재", 1);
    ms.reqCreateRPValue("수해", 1);
    ms.reqCreateRPValue("지진", 1);
    ms.reqCreateRPValue("추락", 1);
    ms.reqCreateRPValue("시작", 1);
    ms.reqCreateRPValue("정지", 1);

    ms.reqCreateConstraints(" ");
    ms.reqCreateConstraints(" ");
    ms.reqCreateConstraints(" ");
    ms.reqCreateConstraints(" ");
    ms.reqCreateConstraints(" ");
    ms.reqCreateConstraints(" ");

    assertEquals(8, ms.rm.calculateTestCaseNum(ms.pm.reqGetVersion()));
}
```

Activity2055. Write Unit Test Code

calculateTestCaseNum

```
@Test
public void testCalculateTestCaseNum2() {
    ms.reqCreateProject("Example 2", 2);

    ms.reqCreateCategory("장애조작", 4);
    ms.reqCreateCategory("시뮬레이션", 2);

    ms.reqCreateRPValue("화재", 1);
    ms.reqCreateRPValue("수해", 1);
    ms.reqCreateRPValue("지진", 1);
    ms.reqCreateRPValue("추락", 1);
    ms.reqCreateRPValue("시작", 1);
    ms.reqCreateRPValue("정지", 1);

    ms.reqCreateConstraints(" ");
    ms.reqCreateConstraints("error");
    ms.reqCreateConstraints(" ");
    ms.reqCreateConstraints("error");
    ms.reqCreateConstraints(" ");
    ms.reqCreateConstraints(" ");

    assertEquals(6, ms.rm.calculateTestCaseNum(ms.pm.reqGetVersion()));
}
```

Activity2055. Write Unit Test Code

calculateTestCaseNum

```
@Test
public void testCalculateTestCaseNum3() {
    ms.reqCreateProject("Example 2", 4);

    ms.reqCreateCategory("시뮬레이션", 2);
    ms.reqCreateCategory("승객 생성", 2);
    ms.reqCreateCategory("모터 출력", 2);
    ms.reqCreateCategory("전체 승객 수", 2);

    ms.reqCreateRPValue(">=0 인 정수", 1);
    ms.reqCreateRPValue("그 외", 1);
    ms.reqCreateRPValue(">=0 인 정수", 1);
    ms.reqCreateRPValue("그 외", 1);
    ms.reqCreateRPValue(">=0 인 정수", 1);
    ms.reqCreateRPValue("그 외", 1);
    ms.reqCreateRPValue(">=0 인 정수", 1);
    ms.reqCreateRPValue("그 외", 1);

    ms.reqCreateConstraints("property OBSFR");
    ms.reqCreateConstraints(" ");
    ms.reqCreateConstraints(" ");
    ms.reqCreateConstraints(" ");
    ms.reqCreateConstraints(" ");
    ms.reqCreateConstraints(" ");
    ms.reqCreateConstraints(" ");
    ms.reqCreateConstraints("if OBSFR");

    assertEquals(12, ms.rm.calculateTestCaseNum(ms.pm.reqGetVersion()));
}
```

Activity2055. Write Unit Test Code

calculateTestCaseNum

```
@Test
public void testCalculateTestCaseNum5() {
    ms.reqCreateProject("Example 2", 3);

    ms.reqCreateCategory("장애조작", 4);
    ms.reqCreateCategory("시뮬레이션", 2);
    ms.reqCreateCategory("승객 생성", 2);

    ms.reqCreateRPValue("화재", 1);
    ms.reqCreateRPValue("수해", 1);
    ms.reqCreateRPValue("지진", 1);
    ms.reqCreateRPValue("추락", 1);
    ms.reqCreateRPValue("시작", 1);
    ms.reqCreateRPValue("정지", 1);
    ms.reqCreateRPValue(">=0 인 정수", 1);
    ms.reqCreateRPValue("그 외", 1);

    ms.reqCreateConstraints("property OBSFR");
    ms.reqCreateConstraints("property OBSFD");
    ms.reqCreateConstraints(" ");
    ms.reqCreateConstraints(" ");
    ms.reqCreateConstraints("if OBSFR");
    ms.reqCreateConstraints(" ");
    ms.reqCreateConstraints("if OBSFD");
    ms.reqCreateConstraints(" ");

    assertEquals(6, ms.rm.calculateTestCaseNum(ms.pm.reqGetVersion()));
}
```

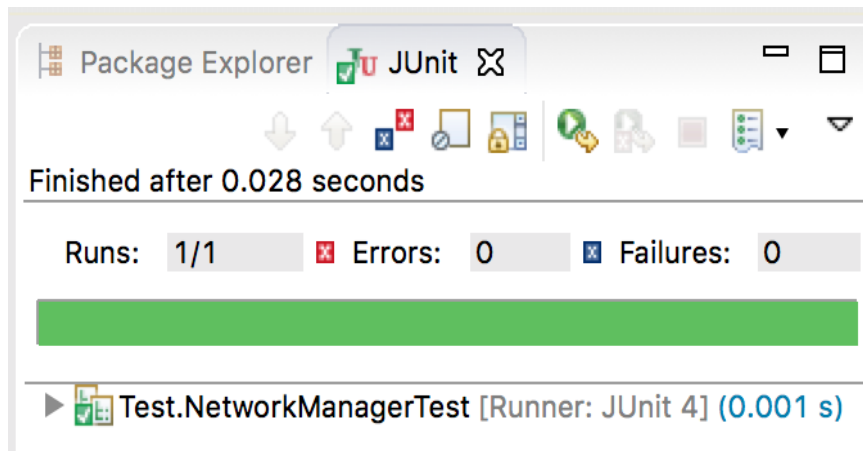

Activity2061. Unit Testing

Login

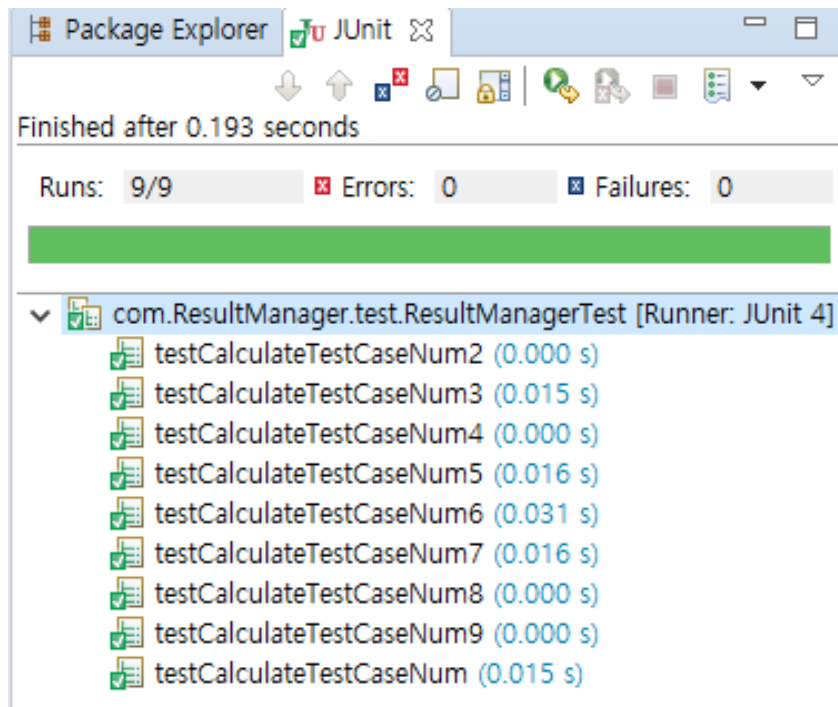

Activity2061. Unit Testing

CalculateTestCaseNum



Activity2063. System Testing

Test Number	Test 항목	Description	Use case	System function
1	Leader 버튼 시험	리더로 로그인이 성공하면 리더 view가 뜨는지 확인한다. 실패하면 창이 안 넘어가는지 확인한다.	Login	R1
2	Member 버튼 시험	멤버로 로그인이 성공하면 멤버 view가 뜨는지 확인한다. 실패하면 창이 안 넘어가는지 확인한다.	Login	R1
3	New Project버튼 시험	프로젝트의 정보를 입력하는 창이 뜨는지 확인한다.	Create Project	R2
4	Send Project 버튼 시험	프로젝트가 멤버에게 전송 되는지 확인한다.	Send Project	R6
5	Add Version버튼 시험	버전을 추가하기 위한 창이 뜨는지 확인한다.	Add Version	R5
6	Open project 버튼 시험	저장되어있는 프로젝트를 탐색할 수 있는 창이 뜨는지, 선택 후 저장된 프로젝트가 열리는지 확인한다.	Open Project	R3

Activity2063. System Testing

Test Number	Test 항목	Description	Use case	System function
7	Save Project 버튼 시험	프로젝트를 저장경로에 저장 시킬 수 있는 창이 뜨는지 확인한다. 프로젝트의 저장이 되는지 확인한다.	Save Project	R4
8	Finish 버튼 시험	테스트케이스가 산출 되는지 확인한다.	Combination TestCase	R7
11	Accept 버튼 시험	멤버에서 리더에게 accept 응답이 전송 되는지 확인한다.	Send Feedback	R9
12	Confirm 버튼 시험	멤버에서 리더에게 피드백 내용이 전송 되는지 확인한다.	Send Feedback	R9
13	Feedback 버튼 시험	리더에서 피드백 버튼을 눌렀을 때, 피드백 내용을 볼 수 있는 창이 뜨는지 확인한다.		

Activity 2067. Testing Traceability Analysis

System Operation	Operation in interaction diagram	method	class	Unit Test	
login()	reqAddversion(categoryNum)	reqAddversion(categoryNum)	MainSystem	TestReqLogin	
createProject()	reqCreateProject(projectName, categoryNum)	reqCreateProject(projectName, categoryNum)			
openProject()	reqCreateCategory(categoryName, RPValueNum)	reqCreateCategory(categoryName, RPValueNum)			
saveProject()	reqCreateRPValue(RPValueName, ConstraintsNum)	reqCreateRPValue(RPValueName, ConstraintsNum)			
addVersion()	reqCreateConstraints(constraintsName)	reqCreateConstraints(constraintsName)			
sendProject()	reqSave()	reqSave()			
combinationTestCase()	reqOpen()	reqOpen()			
showVersion()	reqSend()	reqSend()			
sendFeedback()	reqReceiveFile()	reqReceiveFile()			
calculateTestCaseNum()	reqShowView()	reqShowView()			
receiveFeedback()	reqSendFeedback(feedback)	reqSendFeedback(feedback)	ProjectManager	TestCalculateTestCaseNum	
receiveProject()	reqCombinationTestcase()	reqCombinationTestcase()			
	reqReceiveFeedback()	reqReceiveFeedback()			
	reqLogin(id)	reqLogin(id)			
	createProject(projectName, categoryNum)	createProject(projectName, categoryNum)			
	createCategory(categoryName, RPValueNum)	createCategory(categoryName, RPValueNum)			
	createRPValue(RPValueName, constraintsNum)	createRPValue(RPValueName, constraintsNum)			
	createConstraints(constraintsName)	createConstraints(constraintsName)			
	deserialize(file)	deserialize(file)			
	serialize()	serialize()			
	reqGetVersion()	reqGetVersion()	NetworkManager		
	reqSetFeedback()	reqSetFeedback()			
	sendProject(file)	sendProject(file)			
	reqReceivedFile()	reqReceivedFile()			
	sendFeedback(feedback)	sendFeedback(feedback)			
	reqReceivedFeedback()	reqReceivedFeedback()			
	reqLogin(id)	reqLogin(id)			
	calculateTestCaseNum(version)	calculateTestCaseNum(version)			
	combinationTestCase(version)	combinationTestCase(version)			
	reqSetCategoryNum(categoryNum)	reqSetCategoryNum(categoryNum)			
	reqCreateCategory(categoryName, RPValueNum)	reqCreateCategory(categoryName, RPValueNum)	ResultManager		
	reqCreateRPValue(RPValueName, ConstraintsNum)	reqCreateRPValue(RPValueName, ConstraintsNum)			
	reqCreateConstraints(constraintsName)	reqCreateConstraints(constraintsName)			
	addVersion()	addVersion()			
	getLastVersion()	getLastVersion()			
	reqSetFeedback()	reqSetFeedback()			
	setCategory(categoryName, RPValueNum)	setCategory(categoryName, RPValueNum)			
	reqRPValue(RPValueName, constraintsNum)	reqRPValue(RPValueName, constraintsNum)			
	reqCreateConstraints(constraintsName)	reqCreateConstraints(constraintsName)			
	reqRPValue(RPValueName, constraintsNum)	reqRPValue(RPValueName, constraintsNum)		Project	
	reqCreateConstraints(constraintsName)	reqCreateConstraints(constraintsName)			
	setConstraintsNum(constraintsNum)	setConstraintsNum(constraintsNum)			
	setConstraintsName(constraintsName)	setConstraintsName(constraintsName)			
	loginCheck()	loginCheck()			
	sendProject()	sendProject()			
	sendFeedback(feedback)	sendFeedback(feedback)			
			Version		
				Category	
			RepresentativeValue		
				Server	
			ReceivedThreadInMainServer		

감사합니다.
